

TECHNICAL MANUAL

DESTRUCTION OF CHEMICAL WEAPONS  
AND DEFENSE EQUIPMENT  
TO PREVENT ENEMY USE

---

HEADQUARTERS, DEPARTMENT OF THE ARMY

8 DECEMBER 1982

CHANGE

HEADQUARTERS  
DEPARTMENT OF THE ARMY  
Washington, DC 30 December 1990

NO. 1

**DESTRUCTION OF CHEMICAL WEAPONS AND DEFENSE EQUIPMENT  
TO PREVENT ENEMY USE**

TM43-0002-31, 8 December 1982, is changed as follows:

1. The purpose of this change is to prevent a potential safety hazard.
2. New or changed material in the narrative is indicated by a vertical bar in the margin of the page.
3. Remove old pages and insert new pages as follows.

Remove Pages  
i and ii  
3-3 thru 3-18  
Index 1 and 2

Insert Pages  
i thru iv  
3-3 thru 3-24  
Index 1 and 2

4. File this change sheet in front of the publication for reference purposes.

**By Order of the Secretary of the Army:**

**Official:**

**THOMAS F. SIKORA**  
*Brigadier General, United States Army*  
*The Adjutant General*

**CARL E. VUONO**  
*General, United States Army*  
*Chief of Staff*

Distribution:

To be distributed in accordance with DA Form 34B (block 859), requirements for TM43-0002-31.

**WARNING**

DEATH or severe wounds or burns may result if personnel fail to observe safety precautions. To prevent injury to personnel using dangerous procedures to destroy equipment, observe all warnings concerning demolitions, radioactive materials, high pressures, dangerous chemicals, flying fragments, flammables, incendiaries, and safe distances.

Do not use mechanical means to destroy ammunition. An explosion or release of hazardous materials may result, causing death or injury to personnel. Remove all ammunition from weapons and return to ammunition shipping containers.

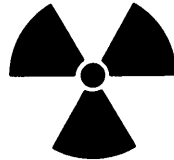

Radiation hazard. Do not use mechanical means, demolition, fire, gunfire, or dumping in water to destroy radioactive sources. Exposure to radiation from the source may cause casualties or deaths.

Always bleed pressurized air from units such as flamethrowers, riot control agent dispersers, breathing apparatus pressure cylinders, or other compressed gas cylinders. Leave valves open after pressurized air is bled from cylinders. Instant release of pressurized air or gas can cause death or injury to personnel.

Always drain wet cell batteries before using any method of destruction. Batteries contain corrosive electrolyte which can cause severe burns.

Drain gasoline from fuel tanks into approved containers. Keep open flame away from destruction area. An unplanned explosion or fire may cause death, injury, or severe burns.

Do not allow DS2 decontaminating agent solution to contact skin or eyes or to be exposed to flame. DS2 is corrosive and combustible. Careless handling may cause severe burns.

Observe applicable surface danger zones specified in AR 385-63 for hazards from incendiary grenades, flamethrowers, incendiary rockets, and demolitions, or from ricochets from gunfire.

Do not use dud ammunition for demolition purposes.

Verify burning rate of each roll of time fuse before use. Burning rates vary with different fuses and moisture content. Allow enough time on installed time fuse for personnel to take cover.

Do not chew or swallow composition C4 explosive. Do not use composition C4 as a heat source or breathe its fumes. Composition C4 is poisonous and gives off poisonous fumes when detonated or burned.

Keep blasting caps, detonating cord, and time fuse separated from explosive charges until ready for use.

Before firing demolition charges, clear all personnel from the surface danger zone to prevent injury from flying fragments. (The surface danger zone is at least 200 meters and up to 500 meters, depending upon the situation.)

**WARNING**

When using demolition or fire as a method of destruction for chemically contaminated equipment (alarms, filters, etc), personnel should mask and move upwind of the site. If unable to move upwind of the site, personnel must wear protective clothing and masks.

Do not burn equipment where fires may ignite ammunition stores. Remove all ammunition from weapons and return to ammunition shipping containers.

Do not smoke within 50 feet of any flammable liquids.

Do not spread gasoline over combustible material to aid in rapid ignition. Gasoline is toxic and very volatile. Because of its low flashpoint, gasoline ignites easily and may explode. Drain gasoline from fuel tanks into approved containers. Keep open flame away from working area until ready to burn equipment.

Do not hold onto or remain close to incendiary grenade after releasing safety lever. Once safety lever is released the grenade will function, This grenade emits incendiary particles, fumes, and intense heat.

Before lighting fires, evacuate all other personnel from the surface danger zone to a safe distance upwind from the equipment to be burned. Take cover immediately after starting fires.

Destroy filled riot control agent dispersers downwind from personnel.

Always remove ignition cylinder from gun group before destroying flamethrower by mechanical means to prevent a premature fire from spilled fuel.

Do not allow chemicals in canisters to contact skin. The chemicals are caustic and may cause burns.

**FIRST AID**

For first aid information, refer to FM 21-11.

## DESTRUCTION OF CHEMICAL WEAPONS AND DEFENSE EQUIPMENT TO PREVENT ENEMY USE

		Paragraph		Page
<b>CHAPTER</b>	<b>1 INTRODUCTION</b>			
Section	I General.....	1-1		1-1
	II Priorities for Destruction.....	1-6		1-1
	III Degree of Damage.....	1-14		1-2
<b>CHAPTER</b>	<b>2 METHODS OF DESTRUCTION</b>			
Section	I General.....	2-1		2-1
	II Destruction by Mechanical Means.....	2-6		2-1
	III Destruction by Demolition.....	2-9		2-2
	IV Destruction by Fire.....	2-12		2-5
	V Destruction by Gunfire.....	2-15		2-8
	VI Destruction by Improper Operation.....	2-18		2-9
	VII Use of Natural Surroundings.....	2-21		2-9
	VIII Combining Methods.....	2-24		2-10
<b>CHAPTER</b>	<b>3 SPECIAL INSTRUCTIONS FOR DESTRUCTION OF CHEMICAL WEAPONS AND DEFENSE EQUIPMENT</b>			
Section	I General.....	3-1		3-1
	II Chemical Weapons and Defense Equipment.....	3-2		3-1
	III Chemical Defense Equipment.....	3-15		3-8
<b>APPENDIX</b>	<b>A REFERENCES</b> .....			A-1
<b>INDEX</b> .....				Index 1

\_\_\_\_\_  
\*This manual supersedes TM43-0002-31, 10 May 1974.

## LIST OF ILLUSTRATIONS

Figure	Title	Page
2-1.	Electric Firing System for Demolition Materials .....	2-4
2-2.	Nonelectric Firing System for Demolition Materials .....	2-5
2-3.	M2 Fire Starter .....	2-7
2-4.	AN-M14 incendiary Grenade Rigged with Lanyard .....	2-8
3-1.	Explosive Charge Location for AN-M14 Series Compressor Unit .....	3-2
3-2.	Explosive Charge Location for M5 Dispenser .....	3-2
3-3.	Explosive Charge Location for M33A1 Dispenser .....	3-2
3-4.	Explosive Charge Location for M2A1-7/M9-7/M9A1-7 Portable flame Thrower . . . . .	3-4
3-5.	Explosive Charge Locations for M3A3 Smoke Generator (deleted) .....	3-4
3-6.	Explosive Charge Locations for M3A4 Smoke Generator .....	3-5
3-7.	Explosive Charge Location for Smoke Grenade Discharger- M239/M250 Smoke Launcher .....	3-5
3-8.	Push Button Unit for M239 Smoke Grenade Launcher .....	3-5
3-9.	Explosive Charge Location for Grenade Stowage Box - M239 Smoke Grenade Launcher .....	3-5
3-10.	Explosive Charge Location for Smoke Grenade Launcher - M243/M257/M259 Smoke Grenade Launcher .....	3-6
3-11.	Arming Firing Unit for M243/M259 Smoke Grenade Launcher .....	3-6
3-12.	Explosive Charge Location for Grenade Storage Box - M243 Smoke Grenade Launcher .....	3-6
3-13.	Explosive Charge Location for NBC Marking Set .....	3-7
3-14.	Explosive Charge Location for M43/M43A1 Detector Unit - M8/M8A1 Chemical Agent Alarm .....	3-9
3-15.	Explosive Charge Location for M42 Alarm Unit - M8/M8A1 Chemical Agent Alarm .....	3-9
3-16.	Explosive Charge Location for BA3517/U battery - M8/M8A1 Chemical Agent Alarm .....	3-9
3-17.	Explosive Charge Locations for M10 and M10A1 power supply - M8/M8A1 Chemical Agent Alarm .....	3-9
3-18.	Explosive Charge Location for Winterization Kit - M8/M8A1 Chemical Agent Alarm .....	3-10
3-19.	Explosive Charge Location for M74/M140 Test Set - M8/M8A1 Chemical Agent Alarm .....	3-10
3-20.	Explosive Charge Locations for M15 Breathing Apparatus .....	3-11
3-21.	Explosive Charge Location for M23/M23A1 Breathing Apparatus .....	3-12
3-22.	Explosive Charge Locations for M18 Gas-Particulate Filter Unit - M10 Collective Protection Equipment (HAWK) .....	3-12
3-23.	Explosive Charge Location for M7 Protective Entrance - M10 Collective Protection Equipment (HAWK) .....	3-13
3-24.	Explosive Charge Locations for M10/M12 Protective Entrance .....	3-13
3-25.	Explosive Charge Locations for M14 Protective Entrance .....	3-14
3-26.	Explosive Charge Location for Filter Unit - M56 Gas-Particulate Filter Unit . . . . .	3-14
3-27.	Explosive Charge Location for Power Distribution Unit - M56 Gas-Particulate Filter Unit .....	3-14
3-28.	Explosive Charge Location for Compartment Control Module - M56 Gas-Particulate Filter Unit .....	3-15
3-29.	Explosive Charge Location for Airflow Valve and Silencer - M56 Gas-Particulate Filter Unit .....	3-15

Figure	Title	Page
3-30.	Explosive Charge Location for Housing Unit - M84 Gas-Particulate Filter Unit .....	3-15
3-31.	Explosive Charge Location for Pump Unit - M12A1 Decontaminating Apparatus .....	3-16
3-32.	Explosive Charge Location for Tank Unit - M12A1 Decontaminating Apparatus .....	3-16
3-33.	Explosive Charge Location for M2 Water Heater - M12A1 Decontaminating Apparatus .....	3-16
3-34.	Explosive Charge Locations for Decontaminating Apparatus, Power-Driven, Portable, Type A/E32U-8 .....	3-17
3-35.	Explosive Charge Location for Decontaminating Apparatus, Power-Driven, Portable, Type A/E32U-8 .....	3-17
3-36.	Cutting Locations for Frame Assembly - M288 Mounting Kit, Smoke Generator .....	3-18
3-37.	Explosive Charge Location for Tank Unit - M288 Mounting Kit, Smoke Generator .....	3-18
3-38.	Explosive Charge Locations for ABC-M6A1 Gas-Particulate Filter Unit .....	3-19
3-39.	Explosive Charge Locations for M9A2/M10A2/M11A2/M12A2 Gas-Particulate Filter Unit - Typical Fixed Installation .....	3-20
3-40.	Thread Area and Canister Cover for Mask: Chemical-Biological, M40, M42, M43 .....	3-21
3-41.	Explosive Charge Location for Battery Housing Unit - Mask, Chemical-Biological: Aircraft, M43 .....	3-21
3-42.	Chemical Agent Monitor and Accessories .....	3-22
3-43.	Explosive Charge Location for Protective Entrance Control Module - Modular Collective Protection Equipment .....	3-23
3-44.	Explosive Charge Location for Power Distribution Unit - Modular Collective Protection Equipment .....	3-23
3-45.	Explosive Charge Location for Control Module - Modular Collective Protection Equipment .....	3-23
3-46.	Explosive Charge Location for Compartment Control Module - Modular Collective Protection Equipment .....	3-23
3-47.	Explosive Charge Location for M5 Converter, Frequency, Static - Modular Collective Protection Equipment .....	3-24
3-48.	Explosive Charge Location for Airflow Valve - Modular Collective Protection Equipment .....	3-24
3-49.	Explosive Charge Locations for M51 Shelter System .....	3-24

# CHAPTER 1 INTRODUCTION

---

## Section I. GENERAL

**1-1. Scope.** This manual is for the guidance of those whose duty it is to render inoperable or destroy equipment which is in imminent danger of capture by an enemy. The instructions contained herein are in accordance with the requirements of STANAG 2113. This manual gives procedures for destroying chemical weapons and defense equipment to prevent enemy use.

**1-2. Reporting of Errors.** You can help to improve this manual by calling attention to errors and by recommending improvements. Your letter or DA Form 2028, Recommended Changes to Publications and Blank Forms, should be mailed directly to: Commander, US Army Armament Materiel Readiness Command, ATTN: DRSAR-MAS-C, Aberdeen Proving Ground, MD 21010. A reply will be furnished directly to you.

**1-3. Authorization.** Only divisional or higher commanders have the authority to order destruction of equipment. They may, however, delegate this authority to subordinate commanders when the situation demands it.

**1-4. Reporting Destruction.** Destruction of equipment will be reported through command channels.

### 1-5. Special Problems.

a. If time permits, select an area where destruction will obstruct enemy movement. Insure that the destruction method used will not create a hazard to personnel from lethal chemical agents, riot control agents, incapacitating agents, incendiaries, smoke, fragments, or ricocheting projectiles.

b. National Command Authority must be given when destruction of lethal chemical agents is intended to obstruct enemy movement, since this could be interpreted as "first use" in violation of Geneva Convention protocol. In all other cases, destruction of lethal chemical agents will be in accordance with TM 3-250.

c. Select the destruction area so as to avoid residual effects and downwind vapor hazards in destruction of chemical munitions. Burning incendiaries, smoke pots, plastics, and rubber items creates a dense cloud of smoke. If weather conditions favor the cloud remaining close to the ground and moving with the wind, consider the tactical advantage or disadvantage of burning.

d. If possible, use natural barricades, such as a hill or woods as protection against fragments and ricochets (TM 3-250 and TM 9-1300-206).

## Section ii. PRIORITIES FOR DESTRUCTION

### 1-6. General.

a. Priority must always be given to the destruction of classified equipment and associated documents.

b. When lack of time or supplies prevents complete destruction of equipment, priority will be given to the destruction of essential parts, and the same parts will be destroyed on all like equipment.

**1-7. Ammunition.** Destroy ammunition in accordance with procedures contained in TM 750-244-5-1 and TM 9-1300-206. Dispose of chemical agents and hazardous chemicals in accordance with TM 3-250.

**1-8. Technical Manuals and Logbooks.** Destroy technical manuals and logbooks with their related equipment.

**1-9. Equipment Installed in Vehicles.** Equipment installed in vehicles should be destroyed in accordance with the priorities for the equipment itself, taking into account the relative importance of the installed equipment and the vehicle itself.



**1-10. Repair Parts.** The same priority for destruction of repair parts of a major item necessary to render that item inoperable must be given to the destruction of similar repair parts in storage areas.

**1-11. Cryptographic Equipment and Material.**

The detailed destruction procedures to be followed in order to insure the rapid and effective destruction of all types of cryptographic equipment and material shall be specified in instructions issued by the appropriate communication security authority. SB 725-1300-1 authorizes specific cryptographic equipment destroyers and other incendiaries for this purpose.

**1-12. Priorities for Destruction of Parts of Military Technical Equipment.**

Priorities for destroying parts of chemical weapons and defense equipment are listed in Chapter 3 under the special instruction for destruction of each item or type of items.

**1-13. Training Equipment and Supplies.**

Destruction of unclassified chemical training equipment and supplies is not required.

### Section III. DEGREE OF DAMAGE

**1-14. Methods of Destruction.** Choose methods of destruction which will cause such damage that it will be impossible to restore the equipment to a usable condition within the combat zone by repair or by cannibalization.

**1-15. Classified Equipment.** Classified equipment must be destroyed in such a degree as to prevent duplication by, or revealing means of operation or function to the enemy.

**1-16. Associated Classified Documents.** Any classified documents, notes, instructions, or other written material pertaining to function, operation, maintenance, or employment including drawings or parts lists, must be destroyed in a manner to render them useless to the enemy. SB 725-1300-1 authorizes the M4 emergency incendiary document destroyer and the M4 incendiary file destroyer for this purpose.

## CHAPTER 2 METHODS OF DESTRUCTION

---

### Section I. GENERAL

**2-1. Introduction.** This chapter contains a brief description of the methods used to destroy chemical weapons, defense equipment, parts, and supplies in the field. Methods that can be used are mechanical means, demolition, fire, gunfire, improper operation, and use of natural surroundings. These methods may be used singly or in combination. In general, mechanical destruction, followed by demolition (use of explosives) or fire (burning with intense heat), will usually render equipment useless to the enemy. The methods used in a given situation will depend upon the time, equipment, and personnel available.

**2-2. Limitations.** The procedures given are for guidance only. The method selected must be realistic depending on the time and means available. The tactical situation, security classification, technical capabilities of personnel, and the quantity and location of equipment must also be considered. The availability of the equipment required for each method may alter the application of a particular method and cause a different method to be used.

**2-3. Boobytrapping.** If time permits, boobytraps can be placed in debris after destruction of equipment is complete. See FM 5-31 for the techniques.

**2-4. Training.** Training does not involve the actual destruction of any materiel, but it does involve the simulated breaking of vital parts; the placing of dummy charges; the placing of dummy or inert incendiary grenades; and the selection of suitable sites for destroying equipment to block the advance of the enemy. Personnel selected to perform demolition of equipment by explosives must have received appropriate demolitions specialist training and be thoroughly familiar with applicable provisions of AR 385-63, FM 5-25, and TM 9-1375-213-12. They may then conduct demonstrations showing unit personnel the techniques of using

demolitions to destroy equipment. Unit training may also include demonstrations on how to build fires and use incendiary grenades to burn equipment. All demonstrations in use of demolitions and incendiary grenades must be conducted in accordance with the policies and procedures prescribed in AR 385-63. The training program must emphasize that time will be critical when equipment must be destroyed to prevent enemy use. Upon completion of training, operators, users, and maintenance specialists should be thoroughly familiar with each step in the appropriate method for destroying equipment and supplies.

### 2-5. Safety Precautions.

#### **WARNING**

DEATH or severe wounds or burns may result if personnel fail to observe safety precautions. To prevent injury to personnel using dangerous procedures to destroy equipment, observe all warnings concerning demolitions, radioactive materials, high pressures, dangerous chemicals, flying fragments, flammables, incendiaries, and safe distances.

- a. The unit commander will enforce all established destruction safety precautions.
- b. At least two persons will be assigned to perform any destruction procedures. No persons other than the number required for safety and efficiency of destruction operations will be permitted in the area. Evacuate all other personnel from the immediate area prior to destroying equipment by mechanical means, demolition, fire, gunfire or improper operation.
- c. Know and observe all warnings when performing destruction operations.

### Section II. DESTRUCTION BY MECHANICAL MEANS

#### 2-6. Mechanical Means.

a. Destruction by mechanical means consists of smashing, hammering, cutting, chopping, puncturing,

ripping, crushing, or breaking critical components of equipment so that it cannot be used.

b. Selection of mechanical means for destruction of equipment will depend on the situation. Refer to Section VIII for combining this method with others. Combining mechanical means with another method is usually more effective than either method alone.

c. Mechanical means of destroying equipment are effective as long as the same parts are destroyed on all like equipment.

d. Mechanical means are not effective for destroying equipment made of heavy steel.

e. The mechanical method of destruction should be completed before using the fire method.

**2-7. Required Materials for Mechanical Means.**

a. Materials required for destruction of equipment by mechanical means are sledge hammers, crowbars, picks, axes, or other heavy tools.

b. Tracked vehicles or cranes maybe used to crush piles of small, breakable items.

**2-8. Procedures for Using Mechanical Means.**



Do not use mechanical means to destroy ammunition. An explosion or release of hazardous materials may result, causing death or injury to personnel. Remove all ammunition from weapons and return to ammunition shipping containers.

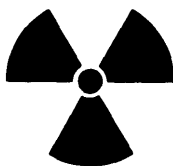

Radiation hazard. Do not use mechanical means, demolition, fire, gunfire, or dumping in water to destroy radioactive sources. Exposure to radiation from the source may cause casualties or deaths.



Always bleed pressurized air from units such as flamethrowers, riot control agent dispersers, breathing apparatus pressure cylinders, or other compressed gas cylinders. Leave valves open after pressurized air is bled from cylinders. Instant release of pressurized air or gas can cause death or injury to personnel.

Always drain wet cell batteries before using any method of destruction. Batteries contain corrosive electrolyte which can cause severe burns.

Drain gasoline from fuel tanks into approved containers. Keep open flame away from destruction area. An unplanned explosion or fire may cause death, injury, or severe burns.

Do not allow DS2 decontaminating agent solution to contact skin or eyes or to be exposed to flame. DS2 is corrosive and combustible. Careless handling may cause severe burns.

a. If time prevents destruction of all parts, smash (or otherwise damage) high priority components first. Render these components completely unusable. Complete destruction of critical parts is more important than light damage to all parts.

b. After critical parts, other parts should be smashed.

c. If time permits, cut or chop protective masks, filters, electrical wiring, nonmetal tubing, hoses, butyl-rubber components, and fabrics.

d. Use tracked vehicles to crush large quantities of lightweight, breakable items.

**Section III. DESTRUCTION BY DEMOLITION**

**2-9. Demolition.**

a. Destruction by demolition requires using explosives and demolition equipment which may not normally be authorized or available. The issue of these materials

and the conditions under which equipment will be destroyed are command decisions. The decisions are made according to the tactical situation of each case.

b. Destruction by demolition requires careful planning and training to insure complete destruction of the equipment. The way in which a demolition charge (TM 9-1375-213-1 2) is placed can make the difference between minor damage or complete destruction. Inexperienced operators using demolition materials improperly can cause serious injuries or death to themselves and/or nearby personnel. Personnel using demolition materials must be thoroughly familiar with pertinent provisions of AR 385-63, FM 5-25, and TM 9-1375-213-12.

c. Demolition charges are used to destroy equipment that cannot be damaged effectively by fire or mechanical means. Demolition charges are most effective for destroying equipment when (1) there is time to place the charges in advance; (2) there are large stores or heavy items of equipment to be destroyed; and (3) simultaneous destruction is planned.

d. Demolition is not effective for destroying small items because they tend to scatter, possibly leaving priority items undestroyed.

e. Another disadvantage of this method is that it requires units to carry explosives and demolition equipment. Further, personnel must be trained in the use of explosives in order to use them effectively and safely.

**2-10. Required Materials for Demolition.** Materials required for destruction of equipment by demolition include demolition charges (explosives such as TNT, tetrytol, or composition C4), detonating cord, firing devices, time fuses, and demolition accessories, kits, and sets. Descriptions and data on these demolition materials are provided in TM 9-1375-213-12. The type and size of demolition charge used may vary according to the time and demolitions available and size of equipment to be destroyed. Most chemical weapons and defense equipment (except lightweight items) can be easily destroyed by using 1/4-pound, 1/2-pound, or 1-pound blocks of TNT demolition charges.

**2-11. Procedures for Using Demolition.** Procedures for using demolition materials to destroy chemical weapons and defense equipment are provided below only as a guide for planning these operations. Do not deviate from the detailed operating procedures in TM 9-1375-213-12. Observe all warnings therein.

**WARNING**

DEATH or severe wounds or burns may result if personnel fail to observe safety precautions.

**WARNING**

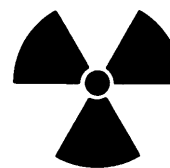

Radiation hazard. Do not use mechanical means, demolition, fire, gunfire, or dumping in water to destroy radioactive sources. Exposure to radiation from the source may cause casualties or deaths.

Observe applicable surface danger zones specified in AR 385-63 for hazards from incendiary grenades, flamethrowers, incendiary rockets, and demolitions or from ricochets from gunfire.

Always drain wet cell batteries before using any method of destruction. Batteries contain corrosive electrolyte which can cause severe burns.

Do not use dud ammunition for demolition purposes.

Verify burning rate of each roll of time fuse before use. Burning rates vary with different fuses and moisture content. Allow enough time on installed time fuse for personnel to take cover.

Do not chew or swallow composition C4 explosive. Do not use composition C4 as a heat source or breathe its fumes. Composition C4 is poisonous and gives off poisonous fumes when detonated or burned.

Keep blasting caps, detonating cord, and time fuse separated from explosive charges until ready for use.

Before firing demolition charges, clear all friendly personnel from the surface danger zone to prevent injury from flying fragments. (The surface danger zone is at least 200 meters and up to 500 meters, depending upon the situation.)

**WARNING**

When using demolition or fire as a method of destruction for chemically contaminated equipment (alarms, filters, etc), personnel should mask and move upwind of the site. If unable to move upwind of the site, personnel must wear protective clothing and masks.

**CAUTION**

Protect time blasting fuses and nonelectric blasting caps from moisture to insure functioning.

a. *Mechanical Destruction.* Smash as many vital components as possible before placing charges on equipment to be destroyed.

b. *Site Preparation.*

(1) Establish surface danger zone of at least 200 meters and up to 500 meters as specified in AR 385-63 and FM 5-25, depending upon size of charge, tactical situation, and terrain.

(2) If time permits and equipment is small, dig hole for equipment to be destroyed.

(3) Place equipment on ground or in hole before placing charges.

c. *Placing Charges.*

(1) Prepare one or more charges of explosive (such as TNT blocks, together with necessary detonating cord), depending upon size and amount of equipment to be destroyed. (Refer to TM 9-1375-213-12.)

(2) Place explosive charges on equipment as specified in Chapter 3.

(3) Connect all charges (if more than one) with detonating cord for simultaneous detonation. Use dual detonating cord ring main lines and branch lines if required by the tactical situation. (Refer to FM 5-25.)

d. *Firing Systems and Priming Charges.* Follow operating procedures in TM 9-1375-213-12, using either electric or nonelectric firing systems and methods for priming charges. Prime each charge as it is placed. Use dual priming to reduce misfires. Select demolition materials for priming charges based upon type of firing system.

(1) For electric firing, use electric blasting caps, electrical wiring, and blasting machines, blasting galvanometers, or equivalent sources of electricity (fig 2-1). Perform prefiring tests. Do not connect wires to electrical source until ready to fire charges.

(2) For nonelectric firing, use nonelectric blasting caps crimped to time blasting fuses (fig 2-2). Always check fuse burning time before crimping on cap.

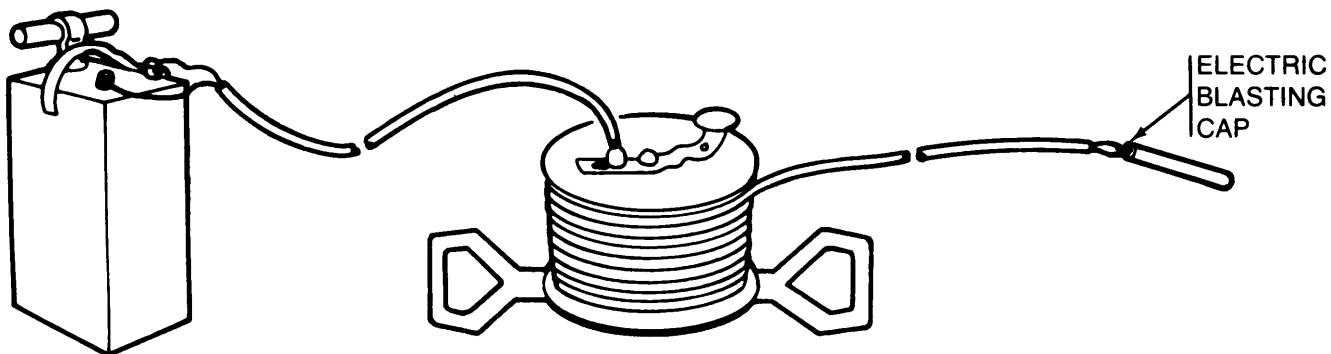

Figure 2-1. Electric Firing System for Demolition Materials.

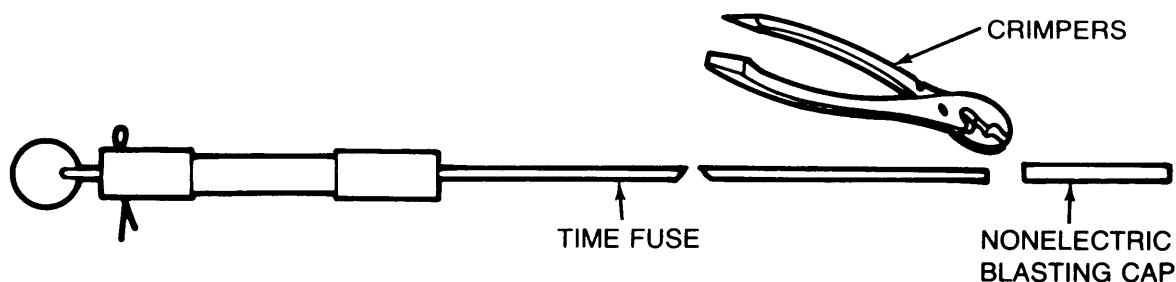

Figure 2-2. Nonelectric Firing System for Demolition Materials.

e. *Detonating Charges.*

(1) Clear all personnel from surface danger zone before firing charges.

(2) If charge is primed with electric blasting cap, take cover before connecting wire to electricity source and firing charges.

(3) If charge is primed with nonelectric blasting cap and time blasting fuse, ignite with igniter or matches and take cover.

f. *Malfunctions Involving Explosives.* Report as prescribed in AR 75-1 and TM 9-1375-213-12.

g. *Defective or Unsatisfactory Nonexplosive Equipment.* Report and turn in as prescribed in TM 38-750 and TM 9-1375-213-12.

## Section IV. DESTRUCTION BY FIRE

### 2-12. Fire.

a. Destruction by fire uses flame and heat to burn or damage equipment. This method uses combustible materials to start the fire and to aid in burning. At unit level, destruction by fire (burning) is the least time-consuming of any destruction method. However, the conditions under which equipment will be burned are command decisions which are made according to the tactical situation.

b. Flame with intense heat will burn most equipment and supplies. Properly concentrating equipment to be burned will provide a hotter, more destructive fire.

c. Heat alone may not always damage equipment. An explosion may prematurely put out a fire. Therefore, mechanical destruction should be completed before a fire is lit.

d. Fires can be built to produce either more heat or more smoke. Heat is desired for destruction; but smoke may be useful for obscuring enemy observation.

e. Destruction by fire can be hazardous. Fires can spread rapidly and become uncontrollable. Intense heat from fires can cause explosions that scatter fragments. Burning equipment may produce dense, toxic smoke. Nearby personnel exposed to intense heat, smoke, or fragments may suffer severe burns, lung damage,

wounds, or death. Observe all safety precautions and warnings (para 2-14) for destruction by fire.

**2-13. Required Materials for Using Fire.** Combustible materials such as brush, scrap wood, empty boxes, rags, paper, oil, and propelling charges can be used for building fires and burning equipment. Ammunition items that have been specifically designed for starting fires and burning equipment should be used when available.

a. *Thickening Compound, Fuel:* M4. M4 thickening compound is used to convert gasoline into thickened flame fuel, an incendiary gel (FM 20-33 and TM 3-366). Thickened flame fuel can be added to combustible materials to produce hotter fires. It can also be projected from flamethrowers to ignite fires and burn equipment from a distance. M4 thickening compound is issued in a 2 1/2-pound can (NSN/DODAC 1365-00-926-4076-K91 7) or in a 25-pound pail (NSN/DODAC 1365-00-143-7139-K920).

b. *Starter, Fire:* NP3, M2. The M2 fire starter is used to start fires in bad weather. It is a small rectangular cellulose nitrate device filled with NP3 incendiary mix. Operating instructions are printed on two sides. Pulling its scratcher wire ignites a matchhead mixture. This ignites the NP3 incendiary mix which burns hotly for about four minutes. The M2 fire starter is issued 500 per box (NSN/DODAC 1370-00-219-8566-L621).

c. *Grenade, Hand: Incendiary, TH3, AN-M14.*

This burning type grenade is used to destroy critical components of equipment and to ignite fires (TM 9-1330-200-12). SB 725-1300-1 authorizes the AN-M14 grenade for this purpose. The AN-M14 grenade is ignited by pulling the safety pin and releasing the safety lever. Its fuze has a delay time of about two seconds. The thermate (TH3) burns with an intense heat of about 4,000°F (2,182 °C) for 30 to 45 seconds. The AN-M14 grenade is issued 16 per box (NSN/DODAC 1330-00-219-8557-G900).

d. *Rocket, Incendiary, 66mm: TPA, 4-Round Clip, M74.* This incendiary rocket, when fired from an M202A1 66mm rocket launcher, is used to ignite fires and burn materiel from a distance (TM 3-1055-456-12).

**2-14. Procedures for Using Fire.**

**WARNING**

DEATH or severe wounds or burns may result if personnel fail to observe safety precautions.

Observe applicable surface danger zones specified in AR 385-63 for hazards from incendiary grenades, flamethrowers, incendiary rockets, and demolitions, or from ricochets from gunfire.

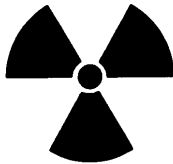

Radiation hazard. Do not use mechanical means, demolition, fire, gunfire, or dumping in water to destroy radioactive sources. Exposure to radiation from the source may cause casualties or deaths.

Do not burn equipment where fires may ignite ammunition stores. Remove all ammunition from weapons and return to ammunition shipping containers.

Always bleed pressurized air from units such as flamethrowers, riot control agent

**WARNING**

dispensers, breathing apparatus pressure cylinders, or other compressed gas cylinders. Leave valves open after pressurized air is bled from cylinders. Instant release of pressurized air or gas can cause death or injury to personnel.

Do not smoke within 50 feet of any flammable liquids.

Do not spread gasoline over combustible material to aid in rapid ignition. Gasoline is toxic and very volatile. Because of its low flashpoint, gasoline ignites easily and may explode. Drain gasoline from fuel tanks into approved containers. Keep open flame away from working area until ready to burn equipment.

Do not allow DS2 decontaminating agent solution to contact skin or eyes or to be exposed to flame. DS2 is corrosive and combustible. Careless handling may cause severe burns.

Always drain wet cell batteries before using any method of destruction. Batteries contain corrosive electrolyte which can cause severe burns.

Do not hold onto or remain close to incendiary grenade after releasing safety lever. Once safety lever is released the grenade will function. This grenade emits incendiary particles, fumes, and intense heat.

Before lighting fires, evacuate all other personnel from the surface danger zone to a safe distance upwind from the equipment to be burned. Take cover immediately after starting fires.

When using demolition or fire as a method of destruction for chemically contaminated equipment (alarms, filters etc), personnel should mask and move upwind of the site. If unable to move upwind of the site, personnel must wear protective clothing and masks.

**CAUTION**

Do not set fires near equipment that is to be retained and evacuated. Move this equipment away from burning site.

a. *Mechanical Destruction.* Smash as many vital components as possible before burning equipment.

b. *Combustible Materials.* Fire built with combustible materials is very effective for destroying chemical supplies such as protective masks, butyl-rubber-coated fabric, canvas, filters, canisters, and plastic components. Burning with combustible materials will also destroy electrical equipment including motors, generator armature windings, and wiring, tires, and low-melting-point metal parts. Procedures for building a fire suitable for burning this type of equipment are as follows:

- (1) Gather combustible materials such as scrap lumber, boxes, cartons, or brush.
- (2) If time and terrain permit, place some combustible materials in a hole or hollow where equipment can be safely burned.
- (3) Place up to 2,000 pounds (1,800 kg) of equipment or parts to be burned in a pile.
- (4) Pack enough combustible materials under, around, and over the pile to sustain burning.
- (5) Pour used motor oil, thickened flame fuel or diesel oil over entire pile.
- (6) Check wind direction.
- (7) Clear all other personnel from burning site to area at least 50 meters (55 yards) upwind.

c. *Ignition.* Combustible materials can be ignited by lighting a combustible train consisting of dry sticks, excelsior, or slow-burning propellant; remotely firing an M2 fire starter; remotely firing an incendiary grenade; firing a burst from a flamethrower; launching an M74 incendiary rocket; or a combination of the above.

**NOTE**

Use at least two fire starters to start afire.

d. *Fire Starters.* M2 fire starters (fig 2-3) can be used to ignite combustible trains leading to piles of combustible materials surrounding equipment to be burned. Fire starters can also be placed on the piles and remotely fired as follows:

- (1) Trail lanyard for each fire starter from upwind position at least 10 meters (11 yards) along ground to pile.
- (2) Slip metal handle off end of fire starter, but do not pull scratcher wire.

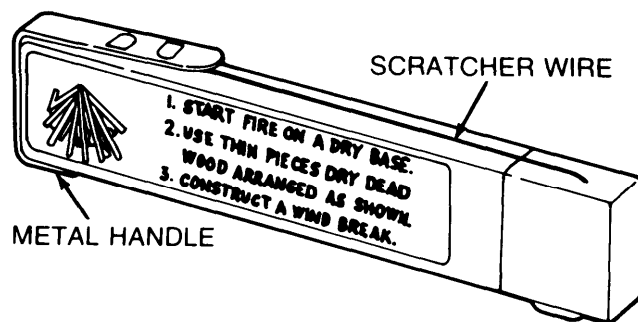

Figure 2-3. M2 Fire Starter.

(3) Tie lanyard to metal handle. Make sure lanyard is slack.

(4) Fasten (tape or tie firmly) fire starter to fuel-soaked equipment at base of pile. (Do not tape or tie scratcher wire down).

(5) Surround fire starter with kindling.

(6) Move back 10 meters (11 yards) from pile and pull lanyards hard to ignite fire starters.

(7) Take cover immediately after starting fires.

e. *Incendiary Grenades.*

(1) Burning with AN-M14 TH3 incendiary hand-grenades is an effective method of destroying essential components of many items. When ignited, the AN-M14 grenade burns intensely. Molten iron from the burning thermate (TH3) will melt metal components, burn through steel plate, and ignite flammable materials.

(2) The grenade can be tossed, ignited in place, or ignited remotely by a lanyard. Always follow the operator's instructions in TM 9-1330-200-12 when employing the AN-M14 incendiary grenade. The grenade should not be tossed except in emergencies. Never hold the AN-M14 grenade in the hand after the safety lever is released. Once the safety lever is released there is no way to stop the grenade from functioning. The fuze has a delay time of about 2 seconds before it ignites the TH3 incendiary mixture.

(3) Igniting the AN-M14 grenade in place is used only when one grenade is needed to destroy an item. Never ignite an AN-M14 incendiary grenade in place to light combustible materials. Lanyards are used to ignite incendiary grenades from a safe distance when starting fires with combustible materials. Lanyards are used to ignite several incendiary grenades at the same time when burning more than one component of an item of equipment or several items. Procedures for using lanyards to remotely ignite AN-M14 TH3 incendiary hand grenades are as follows:

**NOTE**

Use two incendiary grenades to start fires.



(a) Trail lanyard for each grenade from up-wind position at least 10 meters (11 yards) along the ground to the equipment to be burned.

(b) Wire incendiary grenade in upright position over essential part.

(c) Tie lanyard to pull ring on grenade (fig 2-4). Make sure lanyard is slack.

(d) Use pliers to straighten safety pin on grenade. Make sure pull ring is on side leading to other end of lanyard.

(e) Move back 10 meters from equipment and pull lanyards hard to remove safety pins, release levers, and ignite incendiary grenades.

(f) Take cover immediately after starting fires.

f. *Malfunctions Involving Ammunition.* Report as prescribed in AR 75-1 and TM 9-1300-206.

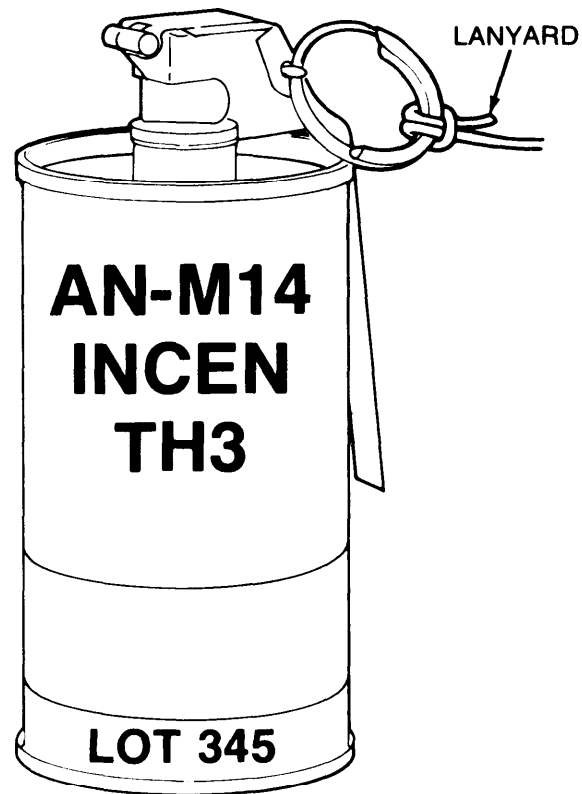

Figure 2-4. AN-M14 Incendiary Grenade Rigged with Lanyard.

## Section V. DESTRUCTION BY GUNFIRE

### 2-15. Gunfire.

a. Destruction by gunfire consists mainly of firing ammunition from weapons so as to hit and destroy the equipment. Gunfire is used when there is not enough time to destroy the equipment by mechanical means or fire or when explosive demolition materials are not available.

b. It is hard to directly hit small items with gunfire. Some items may escape damage serious enough to prevent enemy use. Several hits may be needed to completely destroy essential parts of equipment or supplies.

c. Gunfire creates a hazard of ricochets. Surface danger zones must be observed by all personnel when gunfire is used to destroy equipment.

**2-16. Required Materials for Gunfire.** Materials required for destruction of equipment by gunfire include

individual and unit weapons and related ammunition, Selection of the weapons to be used depends upon time available, type and quantity of weapons and ammunition available, and type and quantity of equipment to be destroyed. To obtain best results when destroying equipment by gunfire, some of the types of weapons and ammunition that can be used are:

a. Flamethrowers projecting thickened flame fuel (para 2-13).

b. Rocket launchers launching incendiary rockets (para 2-13) or antitank rockets.

c. Grenade launchers launching high explosive grenades.

d. Machine guns firing incendiary cartridges.

e. Tanks firing antitank cartridges.

f. Self-propelled guns and howitzers firing high explosive rounds.

g. Artillery firing high explosive rounds.

**2-17. Procedures for Using Gunfire.****WARNING**

DEATH or severe wounds or burns may result if personnel fail to observe safety precautions.



Radiation hazard. Do not use mechanical means, demolition, fire, gunfire, or dumping in water to destroy radioactive sources. Exposure to radiation from the source may cause casualties or deaths.

**WARNING**

Observe applicable surface danger zones specified in AR 385-63 for hazards from incendiary grenades, flamethrowers, incendiary rockets, and demolitions or from ricochets from gunfire.

- a. Select ammunition and weapons that will obtain best results when destroying equipment by gunfire.
- b. Before firing weapons, clear all personnel from the surface danger zone to prevent injury from ricochets.
- c. At ranges of 500 meters or less, fire artillery and launch rockets or grenades from cover.
- d. Fire rounds in salvos or rapid and intense fire to assure enough hits to completely destroy targeted equipment.

**Section VI. DESTRUCTION BY IMPROPER OPERATION****2-18. Improper Operation.**

a. Deliberate abusive, improper operation of certain equipment will damage vital parts such as motors and engines. If hasty destruction becomes necessary, improper operation can be used to damage equipment left behind.

b. This method is not usually as effective or reliable as mechanical means, demolition, or fire.

c. Improper operation will often take too long to be a main method of destruction.

**2-19. Required Materials for Improper Operation.**

Materials required for destruction by improper operation

are common tools, such as wrenches and screwdrivers, and debris, such as sand and dirt.

**2-20. Procedures for Using Improper Operation.**

The procedures below are examples of improper operation and abuse that will damage or destroy engines or motors.

- a. Drain coolants, lubricants, and oil.
- b. Add debris (sand, dirt, etc) to moving parts that have critical tolerances and close fittings.
- c. Leave engines running at full throttle with no load by removing or restraining governor.
- d. Clear personnel from area to protect them from possible flying fragments from engine blowup.

**Section VII. USE OF NATURAL SURROUNDINGS****2-21. Use of Natural Surroundings.**

a. Use natural surroundings such as dense underbrush, caves, holes in the ground, lakes, streams, ponds, bogs, or swamps to scatter, hide, bury, or submerge vital parts of equipment.

b. Using natural surroundings is limited in effectiveness if the enemy carefully searches the area later. Take time to camouflage the burial or hiding places. Burying takes time, labor, and tools to dig holes and cover the items. If water is shallow or clear or apt to dry up, equipment dumped into it maybe easily recovered.

**2-22. Required Materials for Using Natural Surroundings.** Few materials are required for disposing

of equipment by using natural surroundings. If equipment is to be scattered or hidden on land or dumped in water or swamps, the only materials required are those tools needed for disassembly. If equipment is to be buried, picks, shovels and similar equipment are required. If bulldozers are available, they can be used to bury items.

**2-23. Procedures for Using Natural Surroundings.**

- a. Scattering.
  - (1) Disassemble equipment.
  - (2) Scatter parts widely enough in underbrush or deep weeds to prevent regathering.

b. *Burying.*

- (1) Disassemble equipment.
- (2) Bury priority components separately. For example, bury priority one in a different place from priority two.
- (3) Use holes or latrines for burial places.
- (4) Cover equipment with dirt, sand or gravel acquired from diggings. If bulldozers are available, use them to cover large quantities of small items with dirt, sand or gravel.
- (5) Leave as little evidence as possible as to place of burial. Cover with leaves, snow, or other debris. Brush sand, dirt, or snow to disguise burial spot. Drive vehicles over burial area. Remove or scatter spoil left from diggings.

c. *Hiding.*

- (1) Disassemble equipment, if time permits.
- (2) Hide priority parts in caves or rubble.
- (3) Cover and camouflage entrances to caves.

d. *Dumping in Water.*

- (1) Disassemble equipment, if time permits.
- (2) Scatter parts widely in lakes, streams, rivers, swamps, or other bodies of water.
- (3) If time is critical, dump entire item in any body of water which is deep enough to allow equipment to be submerged out of sight and difficult to recover.
- (4) Filters used in chemical-biological protective masks and gas-particulate filter units will also be damaged when submerged in water.

e. *Special Procedures for Destroying Radioactive Sources.*

(1) *Burying.* Burying is the safest method for disposing of radioactive sources in a combat zone. About 7.5 inches of earth will reduce the radiation from the source by a factor of about one-half. If time permits, place the source in a container (piece of pipe, box, or case) for burial. Besides the extra shielding, this will decrease chances of the equipment being broken or contaminated with dirt. This would help preserve the materiel for use if retrieved later. Mark the location of the burial site on a map. Report the location to the local radiation protection officer (AR385-11).

(2) *Scattering or hiding.* Use these methods if time does not permit digging holes for burying the radioactive sources. Mark the location of the hiding places for the burial site on a map. Report the location to the local radiation protection officer (AR385-11).

**WARNING**



Radiation hazard. Do not use mechanical means, demolition, fire, gunfire, or dumping in water to destroy radioactive sources. Exposure to radiation from the source may cause casualties or deaths.

## Section VIII. COMBINING METHODS

**2-24. Combining Methods. Not every situation can** be covered for determining the best combination of methods to destroy equipment. In each case the method or combination of methods must be determined on the basis of existing factors such as: equipment to be destroyed; available time, personnel, and materials required for destruction; and area in which destruction is to take place.

**2-25. Procedures for Combining Methods.**

a. Always attempt to destroy priority parts by mechanical means first. Then destroy the rest of the equipment by demolition or burning. In any case, use mechanical means before using other methods.

b. If equipment is to be buried, hidden, or dumped in water, and time is available, destroy priority parts by mechanical means first.

c. When it is desirable to dump equipment in a body of shallow water, scatter small, vital components so that they will be completely submerged and not easily recovered. Destroy components too large for dumping by demolition, burning, burying, or, if time is critical, leaving them behind. However, do not leave behind any priority parts of any size. If equipment is not completely destroyed, make sure that the enemy cannot make equipment usable by cannibalization.

## CHAPTER 3

# SPECIAL INSTRUCTIONS FOR DESTRUCTION OF CHEMICAL WEAPONS AND DEFENSE EQUIPMENT

---

### Section I. GENERAL

#### 3-1. Special Instructions.

a. *General.* Special instructions in this chapter are divided into two sections. Section II covers chemical weapons and support equipment. Section III covers chemical defense equipment.

b. *Priorities for Destruction.* In most cases, chemical weapons and support equipment will be destroyed before chemical defense equipment. However, if equipment is to be burned using thickened flame fuel (para 2-13), flamethrowers and flame service equipment to support this operation will not be destroyed until the burning mission is completed. Protective equipment such as masks, hoods, and collective protective equipment required for protection of casualties will be either retained or destroyed last. The decision whether to destroy this protective equipment will be made by the division or higher commander. The priorities for destruction of critical components are listed for each item of equipment, as applicable in Sections II and III.

c. *Preferred Methods of Destruction.* Separate paragraphs in each section provide the special instructions for applying the preferred methods of destruction to each item or group of items. Chemical items not specifically covered by these instructions should be destroyed in accordance with procedures for destruction of similar items. Only the preferred methods and specific warnings are listed for the items, General procedures and warnings for each of these methods are covered in Chapter 2. Other methods or a combination of methods may be used as described in Chapter 2.

d. *Mechanical Means.* These procedures are described in paragraph 2-8.

e. *Demolition.* The special instructions for demolition of an item describe where to place explosive charges and indicate the size of each charge required. Accompanying illustrations show where these points are located. (These procedures are described in paragraph 2-11.)

f. *Fire.* The special instructions for destruction by fire consist of burning combustible supplies by building fires and burning individual items using incendiary grenades. In general, incendiary grenades placed and ignited over the same locations as demolition (explosive) charges will burn the critical components of the equipment. (These procedures are described in paragraph 2-14.)

g. *Gunfire.* Gunfire is listed as an alternate, hasty method of destruction. Gunfire includes the use of flamethrowers and incendiary rockets which employ thickened flame fuel to start fires and burn equipment (para 2-14). (These procedures are described in paragraph 2-17.)

h. *Improper Operation.* Procedures for improper operation of specific equipment are included where applicable. (These procedures are described in paragraph 2-20.)

i. *Use of Natural Surroundings.* Burial, scattering, and hiding are the preferred procedures for disposing of radioactive materiel to prevent use by the enemy. (These procedures are described in paragraph 2-23.)

### Section II. CHEMICAL WEAPONS AND SUPPORT EQUIPMENT

**3-2. Chemical Weapons Installed on Vehicles or Aircraft.** Destroying the vehicles will destroy the following items:

FLAME THROWER, MECHANIZED, MAIN ARMAMENT: ABC-M10-8

LAUNCHER, GRENADE, SMOKE: Screening, RP, M239

LAUNCHER, GRENADE, SMOKE: Screening, RP, M243

LAUNCHER, GRENADE, SMOKE: Screening, RP, M250

LAUNCHER, GRENADE, SMOKE: Screening, RP, M257

LAUNCHER, GRENADE, SMOKE: Screening, RP, M259

SERVICE UNIT, FLAME THROWER, TRACKED VEHICLE MOUNTED: M45

SERVICE UNIT, FLAME THROWER, TRUCK MOUNTED: M4A2

SMOKE GENERATING SUBSYSTEM, HELICOPTER: M52

**3-3. Compressor Unit, Reciprocating: Flame Thrower, 3 1/2-cfm, AN-M4, AN-M4B, AN-M4C, and AN-M4D.**

a. *Priorities for Destruction:*

- (1) Engine cylinder
- (2) Compressor cylinders
- (3) Carburetor
- (4) Fuel tank

b. **Preferred Methods of Destruction.** Mechanical means, demolition, fire, and improper operation.

c. **Mechanical Means.** See paragraph 2-8.

d. **Demolition (para 2-11).** Place the explosive charges as follows (fig 3-1). Detonate all charges at same time.

- (1) Fasten 1-pound charge on engine cylinders.
- (2) Fasten 2-pound charge between compressor cylinders.

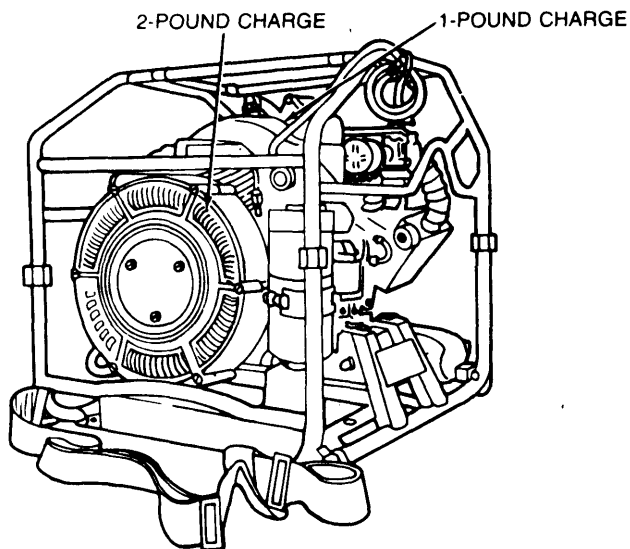

Figure 3-1. Explosive Charge Location for AN-M4 Series Compressor Unit.

e. **Fire (para 2-14).** Fasten and ignite incendiary grenade on top of engine cylinders and compression cylinders.

f. **Improper Operation (para 2-20).** Destroy compressor as follows:

- (1) Remove compressor air intake filters. Pour sand or dirt into intake while compressor is running.
- (2) Remove oil drain plug from oil pan assembly of engine.
- (3) Start engine and run it wide open.

**3-4. Disperser, Riot Control Agent, Helicopter or Vehicle-Mounted: M5.**

**WARNING**

Destroy filled riot control agent dispersers downwind from personnel.

**WARNING**

Always bleed pressurized air from units such as flamethrowers, riot control agent dispersers, breathing apparatus pressure cylinders, or other compressed gas cylinders. Leave valves open after pressurized air is bled from cylinders. Instant release of pressurized air or gas can cause death or injury to personnel.

a. **Priorities for Destruction:**

- (1) Agent tank and pressure regulator
- (2) Gun group
- (3) Hose group

b. **Preferred Methods of Destruction.** Mechanical means, demolition, and fire.

c. **Mechanical Means.** See paragraph 2-8.

d. **Demolition (para 2-11).**

(1) Fasten 1/2-pound explosive charge on top of pressure regulator (fig 3-2).

(2) Tape, tie, or wire disperser gun next to charge.

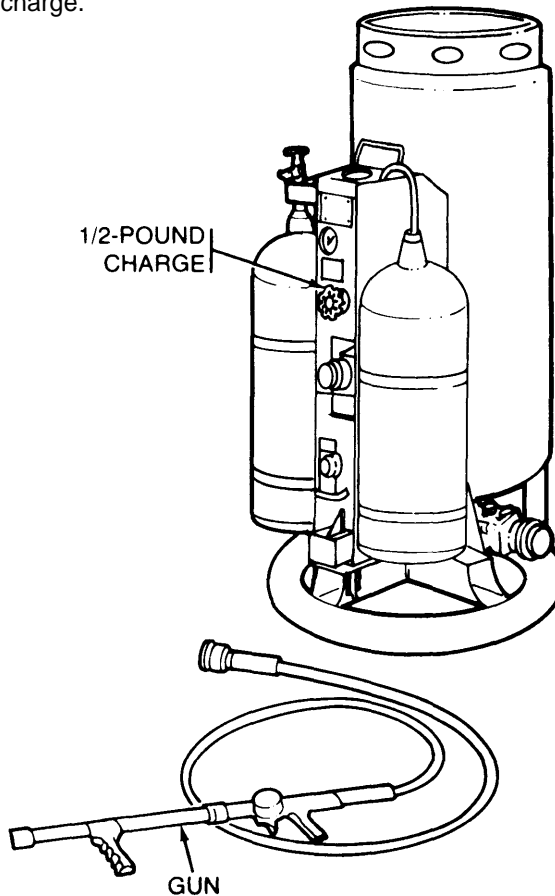

Figure 3-2. Explosive Charge Location for M5 Disperser.

**e. Fire (para 2-14).**

- (1) Lay disperser down and tape, tie, or wire gun to disperser on top of pressure regulator.
- (2) Fasten and ignite incendiary grenade above gun and pressure regulator.

**3-5. Disperser, Riot Control Agent, Portable M3, M33, and M33A1.**

**WARNING**

Destroy filled riot control agent dispersers downwind from personnel.

Always bleed pressurized air from units such as riot control agent dispersers, breathing apparatus pressure cylinders, or other compressed gas cylinders. Instant release of pressurized air or gas can cause death or injury to personnel.

**a. Priorities for Destruction:**

- (1) Agent container and pressure regulator
- (2) Gun group
- (3) Hose group

**b. Preferred Methods of Destruction.** Mechanical means, demolition, and fire.

**c. Mechanical Means.** See paragraph 2-8.

**d. Demolition (para 2-11).**

- (1) Fasten 1/2-pound explosive charge between compressed gas cylinders (fig. 3-3) (agent container and air cylinder).
- (2) Tape, tie, or wire disperser gun next to charge.

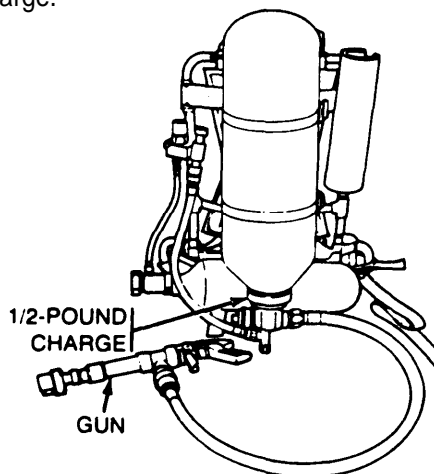

Figure 3-3. Explosive Charge Location for M33A1 Disperser.

**e. Fire (para 2-14).**

- (1) Lay disperser down and tape, tie, or wire gun to disperser above compressed gas cylinders (agent container and air cylinder).
- (2) Fasten and ignite incendiary grenade above gun and compressed gas cylinders.

**3-6. Flame Thrower, Portable: M2A1-7, M9-7, and M9A1-7.**

**WARNING**

Always bleed pressurized air from units such as flamethrowers, breathing apparatus pressure cylinders, or other compressed gas cylinders. Leave valves open after pressurized air is bled from cylinders. Instant release of pressurized air or gas can cause death or injury to personnel.

Always remove ignition cylinder from gun group before destroying flamethrower by mechanical means to prevent a premature fire from spilled fuel.

**a. Priorities for Destruction:**

- (1) High-pressure tank or sphere and regulator
- (2) Gun group
- (3) Fuel tank
- (4) Hose assembly

**b. Preferred Methods of Destruction.** Mechanical means, demolition, and fire.

c. **Mechanical Means.** See Paragraph 2-8.

d. **Demolition (para 2-11).**

- (1) Fasten 1/2 pound explosive charge on top of pressure regulator (figure 3-4).
- (2) Tape, tie, or wire gun next to charge.

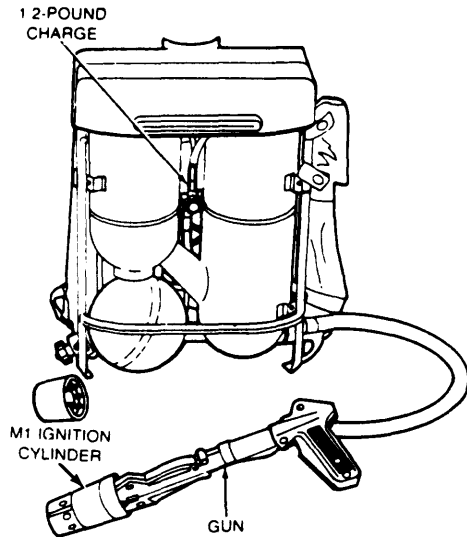

Figure 3-4. Explosive Charge Location for M2A1-7/M9-7/M9A1-7 Portable flame Thrower.

e. **Fire (para 2-14).**

- (1) Lay flamethrower down and tape, tie, or wire gun to flamethrower above pressure regulator.
- (2) Fasten and ignite incendiary grenade above gun and pressure regulator.

**3-7. Generator, Smoke, Mechanical: Pulse Jet, M3A3 (Paragraph deleted).**

**3-8. Smoke Generator, M3A4.**

a. **Priorities Destruction.**

- (1) Engine head assembly
  - (a) Engine head
  - (b) Engine valve
  - (c) Flowjector
- (2) Tool Box Assembly
  - (a) On-board spare engine head assembly
  - (b) On-board spare engine valves
  - (c) On-board spare flowjector
- (3) Engine Manifold
- (4) Fuel float Bowl Assembly
- (5) Magneto Ignition Cable

b. **Preferred Methods of Destruction.** Mechanical means and demolition.

c. **Mechanical Means.**

- (1) Remove engine head assembly from engine manifold. Remove engine valve and flowjector from engine head assembly. Using cutting shears, cut two or more petals from engine valve and cut flowjector in two.

**c. Mechanical means. (Cont'd)**

Cut engine head in two using cutting torch.

(2) Remove on-board spare engine head assembly, engine valves, and flowjector from tool box assembly and destroy as described in preceding paragraph.

(3) Cut magneto ignition cable in two using cutting shears.

**d. Demolition.** Place 1/2 pound explosive charge inside engine manifold and fasten 1/2 pound explosive charge on fuel float bowl assembly as shown in figure and detonate them at the same time.

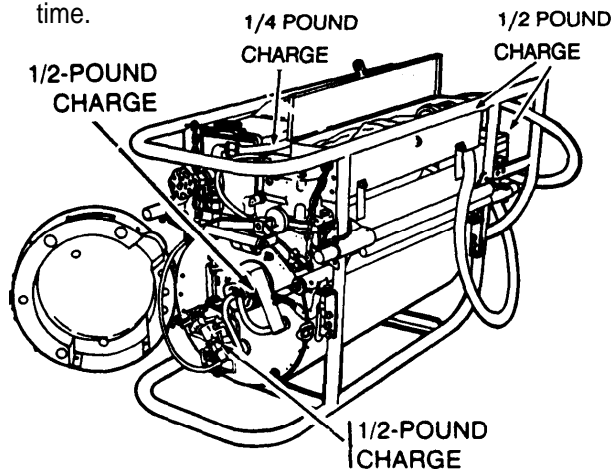

Figure 3-6. Explosive Charge Locations for M3A4 Smoke Generator,

**3-9. Launcher, Grenade, Smoke: Screening, RP, M239 and M250 (not installed).**

**a. Priorities for Destruction:**

- (1) Dischargers
- (2) Push button unit (M239 only)
- (3) Grenade stowage boxes (M239 only)

**b. Preferred Methods of Destruction.** Mechanical means, demolition, and fire.

**c. Mechanical Means.** See paragraph 2-8.

**d. Demolition (para 2-11).** Place explosive charges at the following locations. Detonate them at the same time.

(1) Place 1/2 pound charge in opening between barrels 4 and 5 of each discharger (3-7)

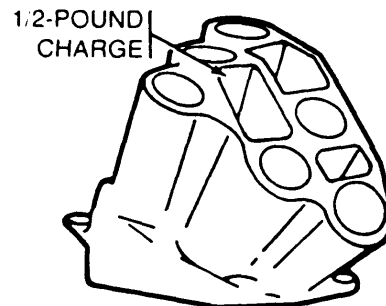

Figure 3-7. Explosive Charge Location for Smoke Grenade Discharger - M239/M250 Smoke Launcher.

(2) Place push button unit (M239 only)(3-8 below) in discharger opening next to charge (3-7 above)

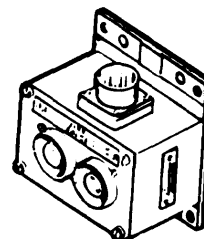

Figure 3-8. Push Button unit for M239 Smoke Grenade Launcher.

(3) place 1/2 pound charge on front of each grenade stowage box (M239 only) (3-9)

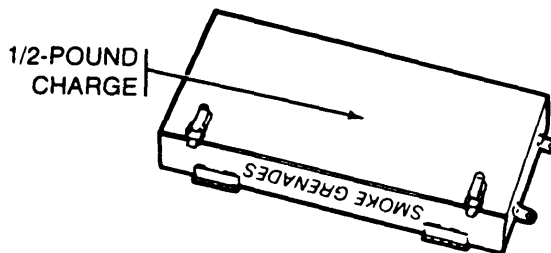

Figure 3-9. Explosive Charge Location for Grenade Stowage Box - M239 Smoke Grenade Launcher.



**e. Fire (para 2-14).** Fasten incendiary grenades at locations specified above. (When destroying push-button unit from M239 launcher, place unit under grenade first.) ignite grenades individually or by using lanyards.

**3-10. Launcher, Grenade, Smoke: Screening, RP, M243, M257 and M259 (not installed).**

**a. Priorities for Destruction:**

- (1) Dischargers
- (2) Arming firing unit (M243 and M259 only)
- (3) Grenade storage boxes (M243 only)

**b. Preferred Methods of Destruction.** Mechanical means, demolition, and fire.

**c. Mechanical Means.** See paragraph 2-8.

**d. Demolition (para 2-11).** Place explosive charges at following locations and detonate at the same time:

- (1) Place 1/2 pound charge between discharger tubes (3-10)

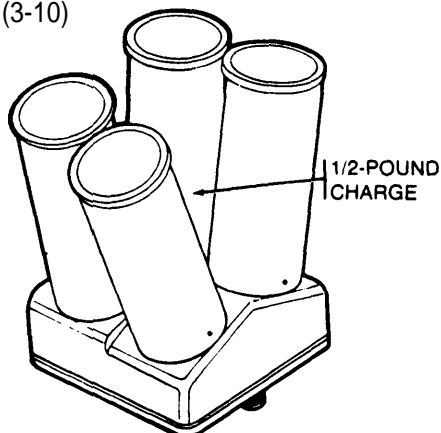

Figure 3-10. Explosive Charge Location for Smoke Grenade Launcher - M243/M257/M259 Smoke Grenade Launcher.

- (2) Place arming firing unit (M243 and M259) (3-11) under charge for one of dischargers (3-11)

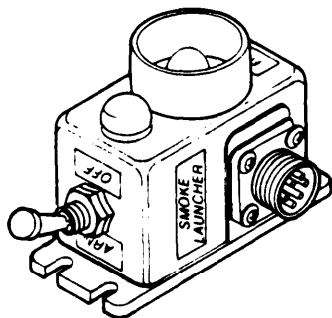

Figure 3-11. Arming Firing Unit for M243/M259 Smoke Grenade Launcher.

- (3) Place 1/2 pound charge on front of grenade storage box (M243 only) (3-12)

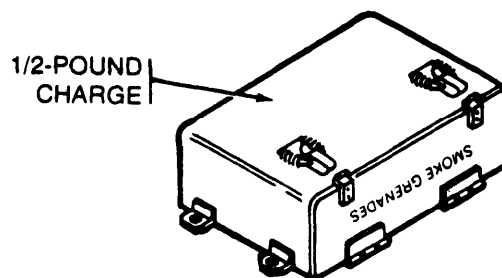

Figure 3-12. Explosive Charge Location for Grenade Storage Box - M243 Smoke Grenade Launcher.

**e. Fire (para 2-14).** Fasten incendiary grenades at locations specified for explosive charges above. (When destroying arming firing unit from M243 or M259 launcher, place unit under grenade first.) ignite grenades individually or by using lanyards.

**3-11. Service Kit, Portable Flame Thrower-Riot Control Agent Disperser: M27.**

**a. Priorities for Destruction:**

- (1) Test gages
- (2) Pressure regulator
- (3) Hoses

**b. Preferred Method of Destruction.** Mechanical means.

**c. Mechanical Means.** See paragraph 2-8.

**3-12. Service Kit, Portable Riot Control Agent Disperser: M254.**

**a. Priorities for Destruction:**

- (1) Pressure check gages
- (2) Charging hose assembly
- (3) Agent transfer tube assembly

**b. Preferred Method of Destruction.** Mechanical means.

**c. Mechanical Means.** See paragraph 2-8.

**3-13. NBC Marking Set.****a. Priorities for Destruction.**

- (1) Flags
- (2) Pales

**b. Preferred Methods of Destruction.** Mechanical means, demolition, and fire.

**c. Mechanical Means.** See paragraph 2-8.

**d. Demolition (para 2-11.)** Fasten 1/4 pound explosive charge at the following location (3-13)

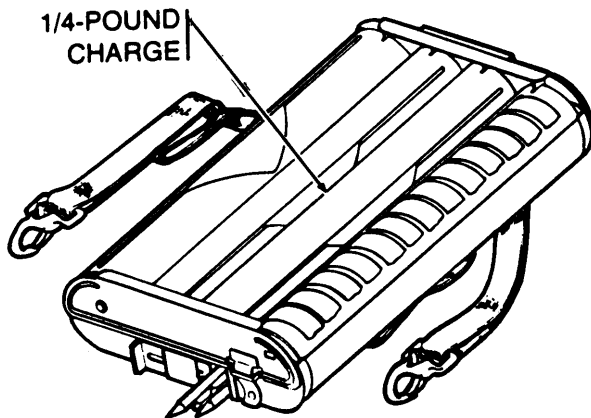

Figure 3-13. Explosive Charge Location for NBC Marking Set.

**e. Fire (para. 2-14).** Fasten incendiary grenade at location specified for charge above and ignite by using lanyards.

**3-14. Smoke Generating Subsystem, Helicopter: M52 (not installed).****a. Priorities for Destruction:**

- (1) Pump and motor assembly
- (2) Oil tank assembly
- (3) Nozzle ring assembly
- (4) Operating switch

**b. Preferred Method of Destruction.** Mechanical means.

**c. Mechanical Means.** See paragraph 2-8.

## Section III. CHEMICAL DEFENSE EQUIPMENT

**3-15. Chemical Defense Equipment installed on Vehicles.** Destroying vehicles will destroy the following items:

ALARM, CHEMICAL AGENT, AUTOMATIC: Portable, Manpack, M8 and M8A1 and Accessories

COLLECTIVE PROTECTION EQUIPMENT, CBR: Battery Control Central, HAWK, M10

ENTRANCE, PROTECTIVE, PRESSURIZED, COLLAPSIBLE: M10

ENTRANCE, PROTECTIVE, PRESSURIZED, COLLAPSIBLE: M12

FILTER UNIT, GAS-PARTICULATE: 200 CFM, 208 V, 400 HZ, M56

FILTER UNIT, GAS-PARTICULATE: Armored Ambulance, M14

FILTER UNIT, GAS-PARTICULATE: 12-CFM, ABC-M8A2 and ABC-M8A3

FILTER UNIT, GAS-PARTICULATE: 20-CFM, M13 and M13A1

**3-16. Alarm, Chemical Agent, Automatic: Portable, Manpack, M8 and M8A1 and Accessories.**



Radiation hazard. Do not use mechanical means, demolition, fire, gunfire, or dumping in water to destroy radioactive sources. Exposure to radiation from the source may cause casualties or deaths.

When using demolition or fire as a method of destruction for chemically contaminated equipment (alarms, filters, etc), personnel should mask and move upwind of the site. If unable to move upwind of the site, personnel must wear protective clothing and masks.

**a. Alarm, Chemical Agent, Automatic: Portable, Manpack, M8 and M8A1.**

DETECTOR UNIT, CHEMICAL AGENT AUTOMATIC ALARM: M43 and M43A1

ALARM UNIT, CHEMICAL AGENT AUTOMATIC ALARM: M42

**b. Accessories.**

BATTERY, DRY, MEDIUM DUTY: BA3517/U

BATTERY, DRY, 1 1/2-VOLT: BA3202 or BA3030/U

BATTERY ASSEMBLY: BB501/U

CABLE ASSEMBLY, POWER, ELECTRICAL: M168

MAINTENANCE KIT, CBR EQUIPMENT: Detector Alarm, M273

MOUNTING KIT, CHEMICAL AGENT AUTOMATIC ALARM: Low Profile, M182

MOUNTING KIT, CHEMICAL AGENT

AUTOMATIC ALARM: High Profile, M288

POWER SUPPLY, CHEMICAL AGENT AUTOMATIC ALARM: M10 and M10A1

REFILL KIT, CHEMICAL AGENT AUTOMATIC ALARM: M229

TEST SET, CHEMICAL AGENT AUTOMATIC ALARM: M74 and M140

WINTERIZATION KIT, AUTOMATIC CHEMICAL AGENT ALARM: M253

**c. Priorities for Destruction.**

(1) M43 and M43A1 detector unit

(2) M42 alarm unit

(3) Batteries, M10 and M10A1 power supply, and M253 winterization kit

(4) M74 and M140 test set

(5) M182 and M228 mounting kits

(6) M229 refill kit and M273 maintenance kit

**d. Preferred Methods of Destruction.** Mechanical means, demolition, and fire. Always remove the cell module from the M43A1 detector unit before using these methods. The M43A1 detector unit cell module contains radioactive material. Discard the cell module in accordance with AR 385-11.

**e. Mechanical Means. See paragraph 2-8.**

**f. Demolition (para 2-11).** Fasten 1/4-pound explosive charges on following items and detonate at onetime.

(1) M43 and M43A1 detector unit. Remove and discard detector cell module from M43A1 detector unit before placing charge. Place charge on top of upper case (3-14)

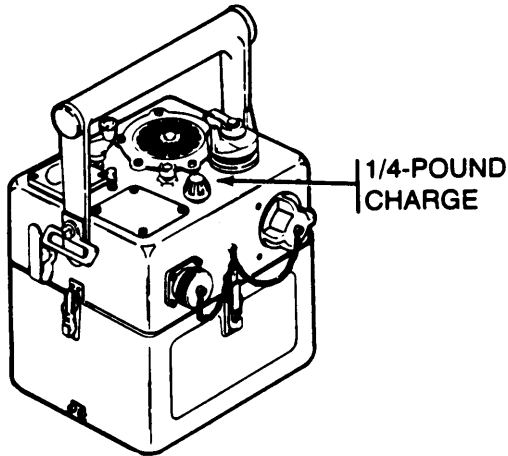

Figure 3-14. Explosive Charge Location for M43/M43A1 Detector Unit - M8/M8A1 Chemical Agent Alarm.

(3) BA3517/U battery. Place charge on top of case (or short connector pins)(3-16)

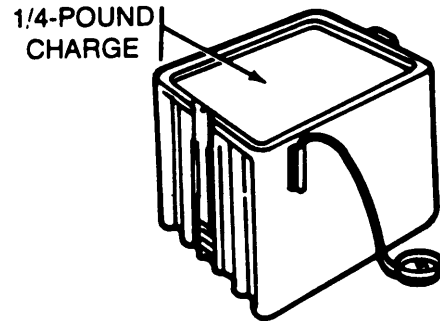

Figure 3-16. Explosive Charge Location for BA3517/U battery - M8/M8A1 Chemical Agent Alarm.

(2) M42 alarm unit. Place charge on top of cover (3-15)

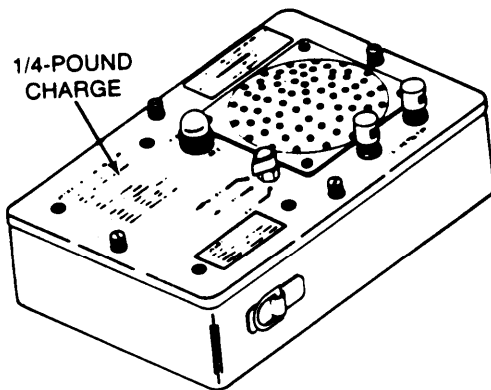

Figure 3-15. Explosive Charge Location for M42 Alarm Unit - M8/M8A1 chemical Agent Alarm.

(4) M10 power supply(3-17 top) and M10A1 power supply (3-17 bottom). Place charge on top of case.

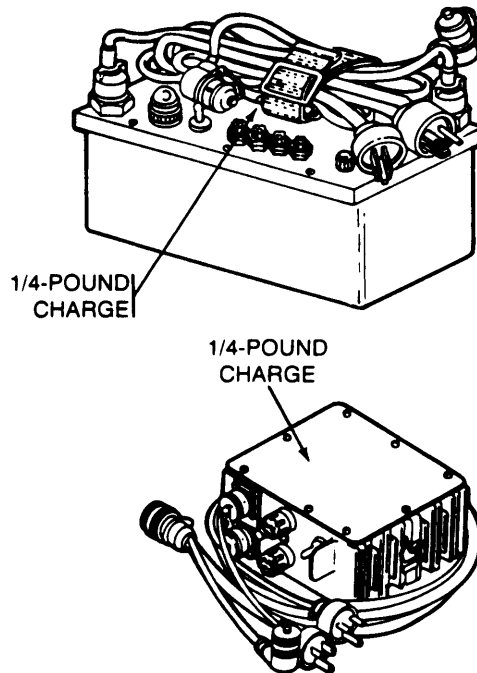

Figure 3-17. Explosive Charge Locations for M10 and M10A1 power supply - M8/M8A1 Chemical Agent Alarm.

(5) M253 winterization kit (3-18) Place charge on top of BB501/U battery assembly and fasten M168 cable assembly to charge.

(6) M74 or M140 test set. Place charge on top of case (3-19)

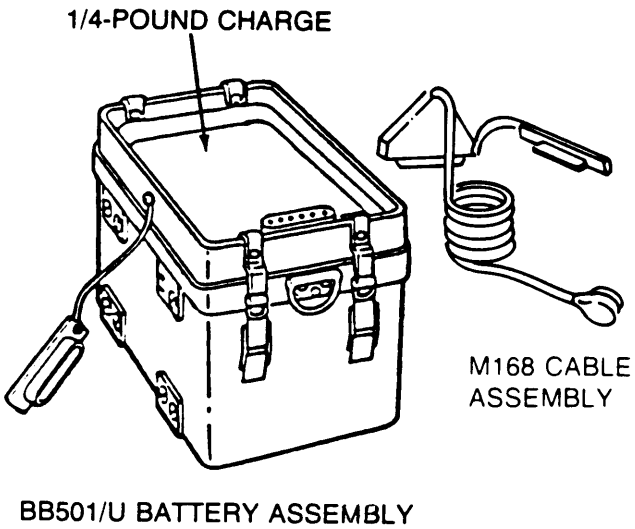

Figure 3-18. Explosive Charge Location for M253 Winterization Kit - M8/M8A1 Chemical Agent Alarm.

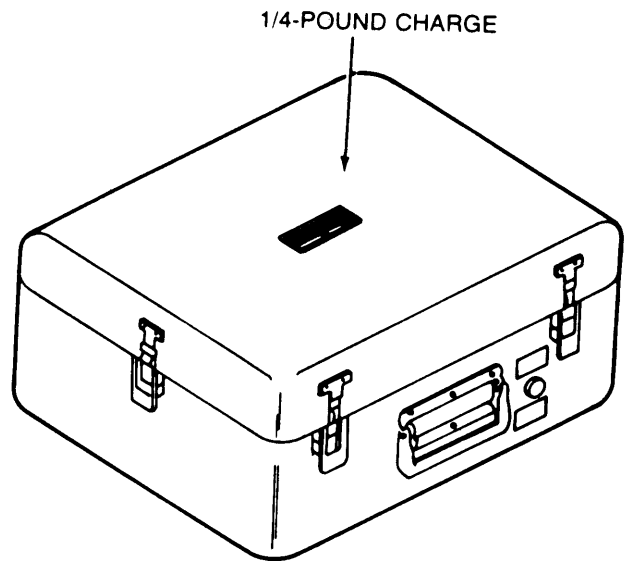

Figure 3-19. Explosive Charge Location for M74/M140 Test Set - M8/M8A1 Chemical Agent Alarm.

**g. Fire (para 2-14).**

(1) If time permits, build fire with combustible materials and ignite using fire starter or incendiary grenade.

(2) For hasty destruction, fasten incendiary grenades at locations specified for explosives above. Ignite grenades by using lanyards.

**3-15. Area Predictor and Calculators.**

**a. Area Predictor**

AREA PREDICTOR, RADIOLOGICAL FALLOUT: ABC-M5A2

**b. Calculators.**

CALCULATOR, DOWNWIND TOXIC VAPOR HAZARD: Line Source, ABC-M3

CALCULATOR, DOWNWIND TOXIC VAPOR HAZARD: Point Source, ABC-M2

CALCULATOR SET, RADIAC AND NUCLEAR YIELD: ABC-M28A1

**c. Preferred Methods of Destruction.** Mechanical means and fire.

**d. Mechanical Means.** Cut or chop into small pieces.

**e. Fire (para 2-14).** Burn with combustible materials. Use kindling and M2 fire starter to burn small quantity.

**3-16. Breathing Apparatus, Compressed Air: M15**

**WARNING**

Always bleed pressurized air from units such as flamethrowers, riot control agent dispersers, and breathing apparatus pressure cylinders. Leave valves open after pressurized air is bled from cylinders. Instant release of pressurized air or gas can cause death or injury to personnel.

**a. Priorities for Destruction.**

- (1) Demand regulator
- (2) Pressure regulator
- (3) Facepiece group

**b. Preferred Methods of Destruction:** Mechanical means, demolition, and fire.

**c. Mechanical Means.** See paragraph 2-8.

**d. Demolition (para 2-11).**

(1) Lay apparatus down.

(2) Fasten 1/2-pound explosive charges on end of pressure cylinders (fig 3-20) next to pressure regulator and dummy head.

(3) Place demand regulator and facepiece between charges.

(4) Detonate all charges at the same time.

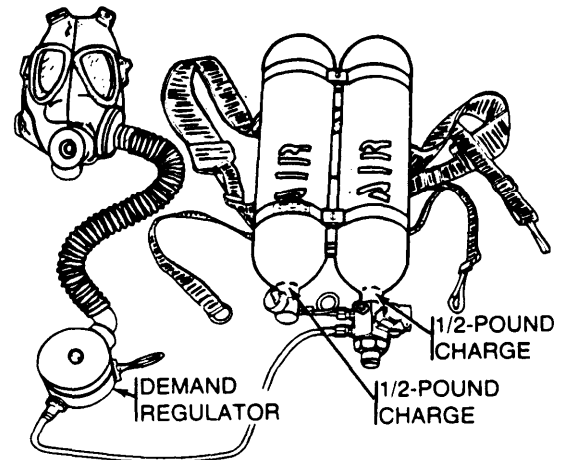

Figure 3-20. Explosive Charge Locations for M15 Breathing Apparatus.

**e. Fire (para 2-14).**

(1) Fasten incendiary grenades at locations specified for charges above.

(2) Place facepiece and demand regulator under grenades and ignite.

**3-17. Breathing Apparatus, Oxygen-Generating: M20 and M20A1.**

**WARNING**

Do not allow chemicals in canisters to contact skin. The chemicals are caustic and may cause burns.

**a. Priorities for Destruction:**

- (1) Canisters
- (2) Facepiece group
- (3) Breathing bag
- (4) Hood

**b. Preferred Methods of Destruction.** Mechanical means and fire.

- c. **Mechanical Means.** See paragraph 2-8.
- d. **Fire (para 2-14).** Burn with combustible materials.

**3-18. Breathing Apparatus, Self-Contained: M23 and M23A1.**

**WARNING**

Always bleed pressurized air from units such as flamethrowers, riot control agent dispersers, breathing apparatus pressure cylinders, or other compressed gas cylinders. Leave valves open after pressurized air is bled from cylinders. Instant release of pressurized air or gas can cause death or injury to personnel.

- a. **Priorities for Destruction:**
  - (1) Pressure-demand regulator
  - (2) Pressure reduction valve
  - (3) Facepiece group
- b. **Preferred Methods of Destruction:** Mechanical means, demolition, and fire.
- c. **Mechanical Means:** See paragraph 2-8.
- d. **Demolition (para 2-11):**
  - (1) Lay apparatus down.
  - (2) Fasten 1/2-pound explosive charge on pressure reduction valve next to compressed air cylinder (fig 3-21).
  - (3) Place pressure-demand regulator and facepiece group over charge and detonate.

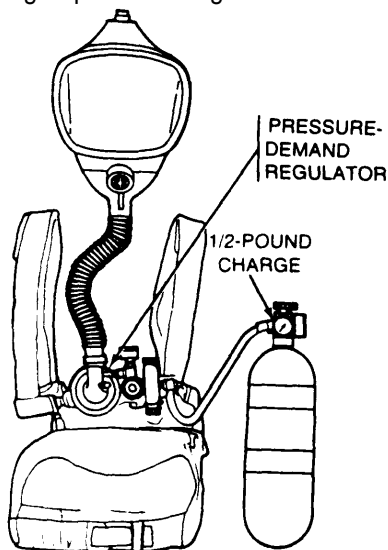

Figure 3-21. Explosive Charge Location for M23/M23A1 Breathing Apparatus.

- e. **Fire (para. 2-14):**
  - (1) Fasten incendiary grenade at location specified for charge above.
  - (2) Place pressure-demand regulator and facepiece group under pressure reduction valve.
  - (3) Ignite grenade.

**3-19. Collective Protection Equipment, CBR: Battery Control Central, HAWK, M10 (not installed).**

**WARNING**

When using demolition or fire as a method of destruction for chemically contaminated equipment (alarms, filters, etc.), personnel should mask and move upwind of the site. If unable to move upwind of the site, personnel must wear protective clothing and masks.

- a. **Priorities for Destruction:**
  - (1) Vaneaxial fan
  - (2) Filters
  - (3) Plenums
  - (4) Fabric enclosure and frame
- b. **Preferred Methods of Destruction.** Mechanical means, demolition, and fire.
- c. **Mechanical Means.** See paragraph 2-8.
- d. **Demolition (para 2-11).** Fasten 1/2-pound explosive charges at as many of the following locations as time permits. Detonate all charges at the same time.
  - (1) M18 gas-particulate filter unit (fig 3-22). Place charges directly below vaneaxial fan, in inlet plenum, on center of lower exhaust plenum, and in prefilter.

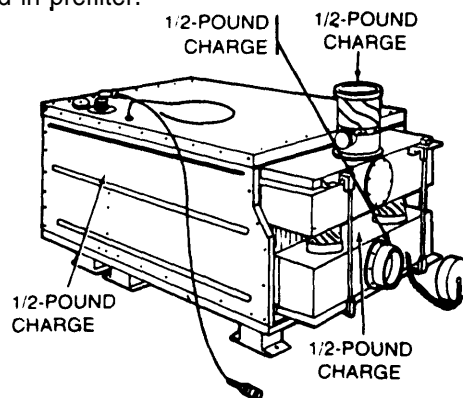

Figure 3-22. Explosive Charge Locations for M18 Gas-Particulate Filter Unit - M10 Collective Protection Equipment (HAWK).

(2) M7 protective entrance (fig 3-23). Tape charge to door-tensioning assembly.

**NOTE**

Entrance may be either collapsed or erected as shown.

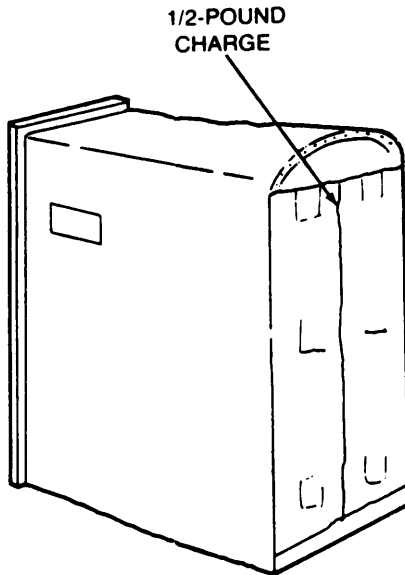

Figure 3-23. Explosive Charge Location for M7 Protective Entrance - M10 Collective Protection Equipment (HAWK).

**e. Fire (para 2-14).**

- (1) Fasten two incendiary grenades at or above each location specified for charges above.
- (2) Ignite grenades by using lanyards.

**3-20. Entrance, Protective, Pressurized, Collapsible: M10 and M12.**

**WARNING**

When using demolition or fire as a method of destruction for chemically contaminated equipment (alarms, filters, etc.) personnel should mask and move upwind of the site. If unable to move upwind of the site, personnel must wear protective clothing and masks.

**a. Priorities for Destruction:**

- (1) Control module
- (2) Fabric enclosure and frame

**b. Preferred Method of Destruction.** Mechanical means, demolition, and fire.

**c. Mechanical Means.** See paragraph 2-8.

**d. Demolition (para 2-11).** Place 1/4-pound charges on door, in each air duct port, and on control module inside entrance port (fig 3-24). Detonate charges at the same time.

**NOTE**

If entrance is collapsed, place 2-pound charge on top.

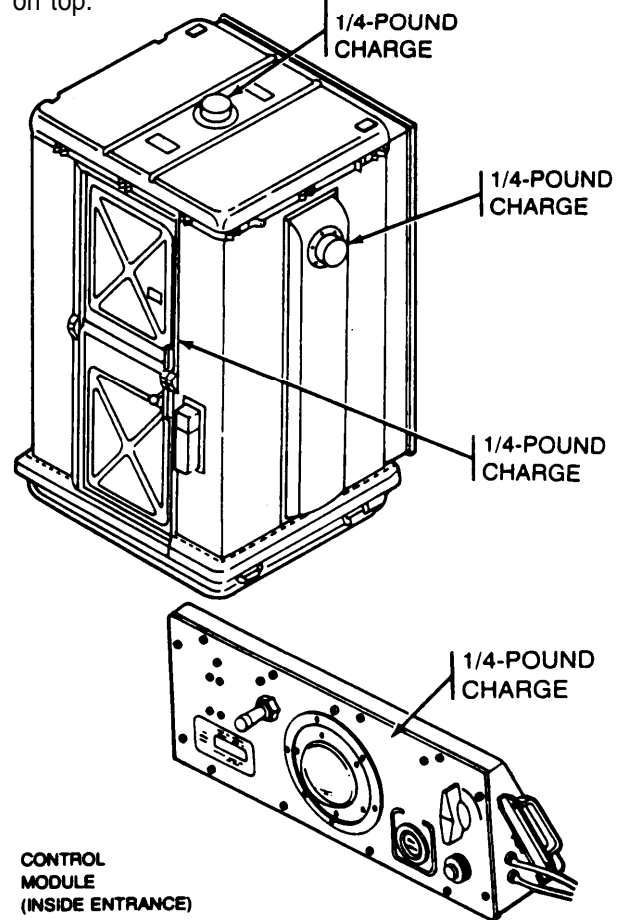

Figure 3-24. Explosive Charge Locations for M10/M12 Protective Entrance.

**e. Fire (para 2-14).** Fasten incendiary grenade at each location specified for charges above and ignite by using lanyards.



**3-21. M14 Entrance: Protective, Pressurized, Collapsible**

**a. Priorities for Destruction:**

(1) Fabric enclosure and frame.

**b. Preferred Methods of Destruction:** Mechanical means, demolition, and fire.

**c. Mechanical Means:** See paragraph 2-8.

**d. Demolition (para. 2-11):** Fasten 1/4 pound explosive charge to the following locations.

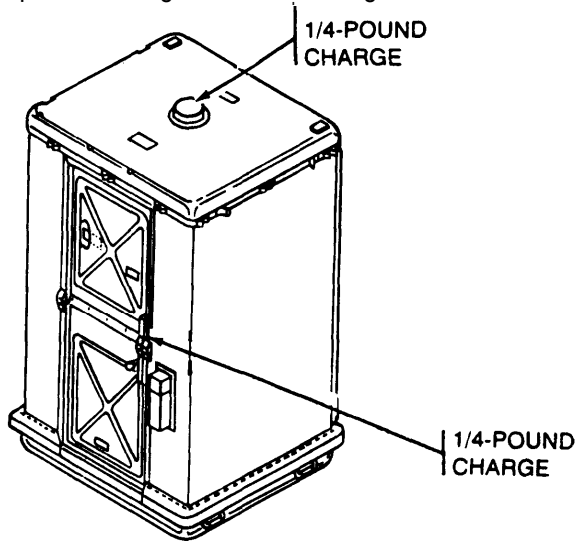

Figure 3-25. Explosive Charge Locations for the M14 Protective Entrance.

**e. Fire (para. 2-14):** Fasten incendiary grenade at each location specified for charges above and ignite by using lanyards.

**3-22. Filter Unit, Gas-Particulate: 200 cfm, 208V, 400 HZ, M56.**

**WARNING**

When using demolition or fire as a method of destruction for chemically contaminated equipment (alarms, filters, etc). personnel should mask and move upwind of the site. If unable to

move upwind of the site, personnel must wear protective clothing and masks.

**a. Priorities for Destruction:**

(1) Blower fan.

(2) Filters.

(3) Power distribution unit

(4) Compartment control module

(5) Airflow valve and silencer

(6) Housing Unit -(M59 GPFU & M84 GPFU 200 cfm only)

**b. Preferred Methods of Destruction.** Mechanical means, demolition, and fire.

**c. Mechanical Means.** See paragraph 2-8.

**d. Demolition (para 2-11).** Fasten explosive charges at as many of the following locations as time permits. Detonate all charges at the same time.

(1) Filter unit. Place 1-pound charge on top (fig 3-26).

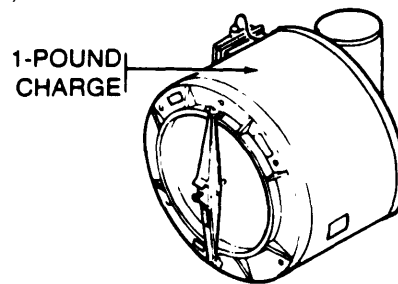

Figure 3-26. Explosive Charge Location for Filter Unit - M56 Gas-Particulate Filter Unit.

(2) Power distribution unit. Place 1/4 pound charge on top (fig 3-27).

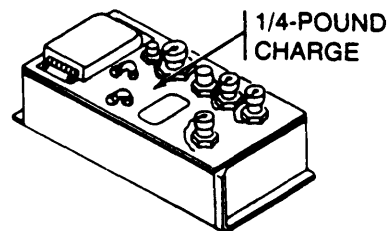

Figure 3-27. Explosive Charge Location for Power Distribution Unit - M56 Gas-Particulate Filter Unit.

(3) Compartment control module. Place 1/4-pound charge on top (3-28)

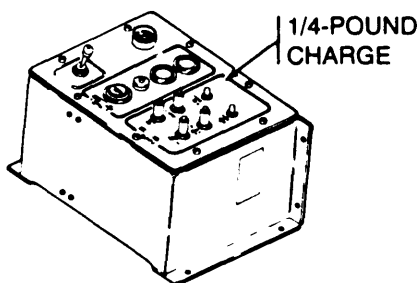

Figure 3-28. Explosive Charge Location for Compartment Control Module-M56 Gas-Particulate Filter Unit.

(4) Airflow valve and silencer. Place 1/4-pound charge between valves and silencer (3-29)

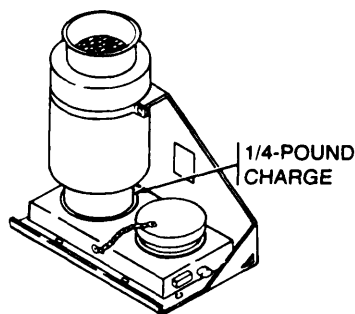

Figure 3-29. Explosive Charge Location for Airflow Valve and Silencer - M56 Gas-Particulate Filter Unit.

(5) Housing Unit (M84 GPFU 200 cfm & M59 GPFU (not featured)). Fasten 1-pound charge at the following location (3-30)

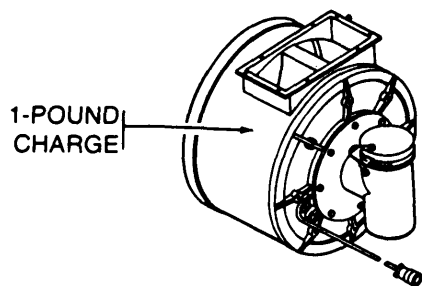

Figure 3-30. Explosive Charge Location for Housing Unit-M84 Gas-Particulate Filter Unit.

**e. Fire (para 2-14).** Fasten incendiary grenade at each location specified for charges above and ignite using lanyards.

3-23. Decontaminating Apparatus, Portable: ABCOM11 and M13.

**WARNING**

Do not allow DS2 decontaminating agent solution to contact skin or eyes or to be exposed to flame. DS2 is corrosive and combustible. Careless handling may result in severe burns.

**a. Preferred Method of Destruction.** Mechanical means.

**b. Mechanical Means (para 2-8).**

- (1) Discharge nitrogen cylinder (M11 only)
- (2) Drain DS2 solution from cylinder.
- (3) Smash metal components.

3-24. Decontaminating Apparatus, Power Driven, Skid-Mounted: 500 gal, M12A1.

**a. Priorities for Destruction.**

- (1) Pump Unit.
  - (a) Controls
  - (b) Engine
  - (c) Starter motor
  - (d) Generator
  - (e) Valves, piping and hoses
- (2) Tank Unit.
  - (a) Tank
  - (b) Valves, piping and hoses
- (3) M2 Water heater.
  - (a) Fuel and ignition drive motor
  - (b) Magneto
  - (c) Fuel pump
  - (d) Control box components
  - (e) Combustion air blower and fan assembly

**b. Preferred Methods of Destruction.** Mechanical means, demolition, and fire.

**c. Mechanical Means.** See paragraph 2-8.

**d. Demolition (para 2-11).** Fasten explosive charges as follows and detonate them at the same time.

(1) Pump unit. Remove and discard panel. Place 2-pound charge under gasoline engine flywheel (3-31)

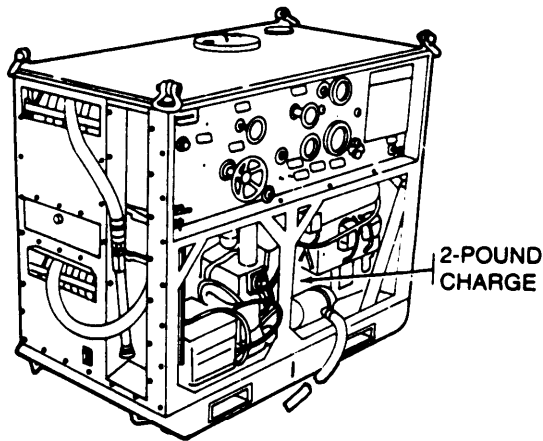

Figure 3-31. Explosive Charge Location for Pump Unit - M12A1 Decontaminating Apparatus.

(2) Tank unit (3-32) Drain tank and place 1-pound charge on drain valve. Remove and discard cover and screen. Place 2-pound charge on hopper-blender inside tank.

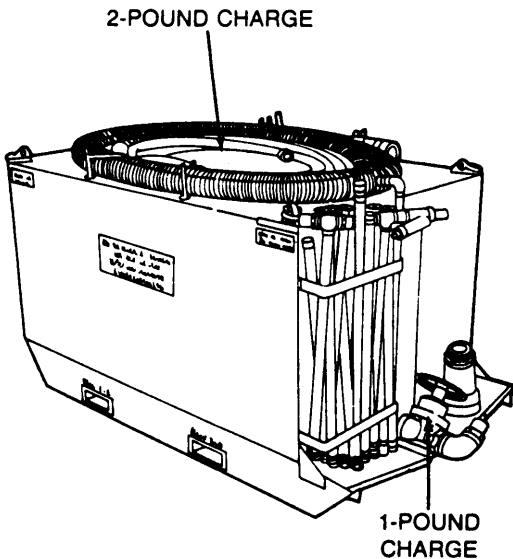

Figure 3-32. Explosive Charge Location for Tank Unit - M12A1 Decontaminating Apparatus.

(3) M2 water heater. Open lid and place 2-pound charge on top of heater (3-33) Do not close lid.

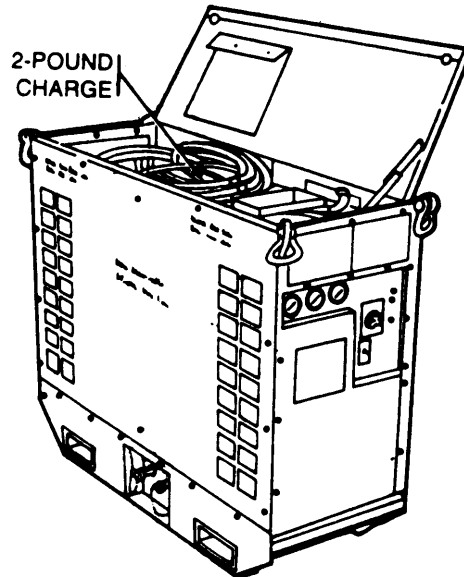

Figure 3-33. Explosive Charge Location for M2 Water Heater - M12A1 Decontaminating Apparatus.

**e. Fire (para 2-14).**

- (1) Fasten incendiary grenades above key components.
- (2) Build fire with combustible materials.
- (3) ignite grenades using lanyards.

**3-25. Decontaminating Apparatus, Type A/E32U-8 and M17.**

**a. Priorities for Destruction.**

- (1) Pumper/Heater Assembly
  - (a) Engine Cylinder
  - (b) Water Pump Case
  - (c) Heat Exchanger
  - (d) Electrical Module
- (2) Accessory Case
  - (a) Spray Wands
  - (b) Shower Bars
  - (c) Hoses
- (3) Water Tank

**b. Preferred Methods of Destruction.** Mechanical means, demolition, and fire.

**c. Mechanical Means.** See paragraph 2-8. Concentrate on the control module and wires in the junction boxes.

**d. Demolition (para 2-11).** Place as many charges (3-34) as time permits. Detonate all charges at the same time.

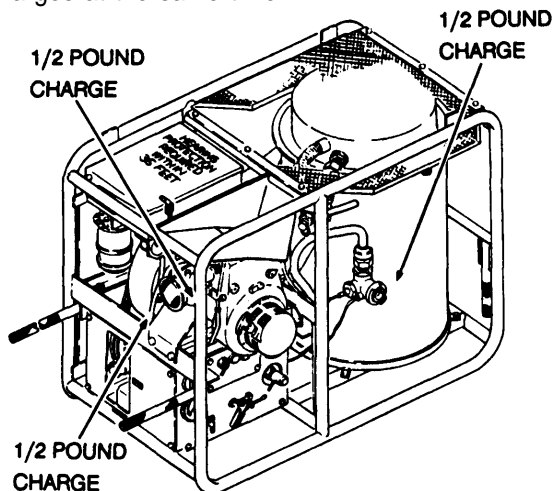

Figure 3-34. Explosive Charge Locations for Decontaminating Apparatus, Power-Driven, Portable, Type A/E32U-8 and M17.

(1) Fasten 1/2 pound charge to the engine cylinder adjacent to the carburetor.

(2) Fasten 1/2 pound charge to the back of the water pump case.

(3) Fasten 1/2 pound charge to the heat exchanger adjacent to the water outlet assembly.

**e. Fire (para 2-14).** Fasten incendiary grenade to engine carburetor, and among burner fuel hoses (3-35) and ignite with lanyard.

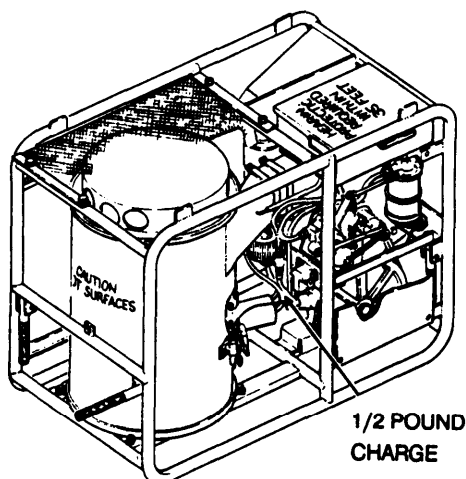

Figure 3-35. Explosive Charge Location for Decontaminating Apparatus, Power-Driven, Portable, Type A/E32U-8.

### 3-26. Detector Sampling Kits and Supplies.

- a. Detector Kits.  
DETECTOR KIT, CARBON MONOXIDE, COLORMERIC: M23  
DETECTOR KIT, CHEMICAL AGENT: ABC-M18A2  
DETECTOR KIT, CHEMICAL AGENT: M256, M258A1
- b. Detector Paper.  
PAPER, CHEMICAL AGENT DETECTOR: VGH, ABC-M8  
PAPER, CHEMICAL AGENT DETECTOR: M9
- c. Refill Kits.  
REFILL KIT, ANALYZING COMPONENTS, CBR AGENTS SAMPLING AND ANALYZING KIT: M33  
REFILL KIT, CHEMICAL AGENT DETECTOR: VG Components, ABC-M30A1
- d. sampling and Analyzing Kits.  
SAMPLING AND ANALYZING KIT, CBR AGENT: M19  
SAMPLING KIT, CBR AGENT: M34  
WATER TESTING KIT, CHEMICAL AGENTS: AN-M2  
WATER TESTING KIT, CHEMICAL AGENTS: M272

**e. Preferred Methods of Destruction.** Mechanical means and fire combined.

**f. Mechanical Means (para 2-8).** Smash breakable components.

**g. Fire (para 2-14).** Burn remaining components with combustible materials.

### 3-27. M291 Skin Decon Kit.

**a. Priority for Destruction.** Each decon packet contained within each kit.

**b. Preferred Method of Destruction.** Mechanical means.

**c. Mechanical Means.** Cut each decon packet in two using cutting shears.

### 3-28. M258A1 Skin Decon Kit, M280 Equipment Decon Kit.

Since both of these items contain hazardous waste, they should be turned into the DRMO for proper destruction and disposal as hazardous waste.

**3-29. M288 Mounting Kit.**

**a. Priorities for Destruction.**

- (1) Fog Oil Tank
- (2) Frame Assembly
- (3) Mounting Cage Assembly

**b. Preferred Methods of Destruction.** Mechanical means and demolition.

**c. Mechanical Means.** Concentrate on the frame and mounting cage assemblies. Using cutting torch, cut angle iron supports as shown in figure.

**d. Demolition.** Drain fog oil tank first if possible. Fasten 1/2 pound explosive charge to side of fog oil tank as shown in figure and detonate.

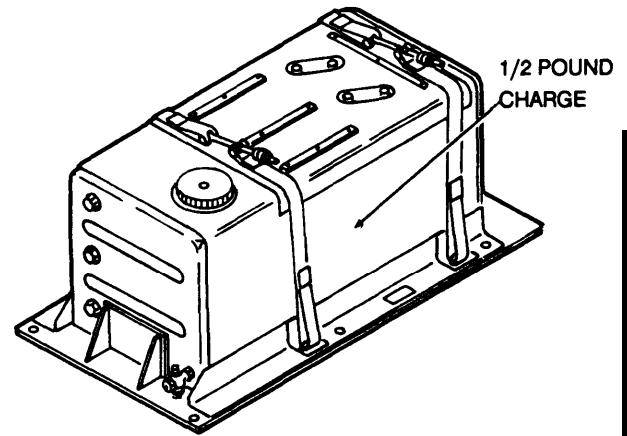

Figure 3-37. Explosive Charge Location for Tank Unit - M288 Mounting Kit, Smoke Generator.

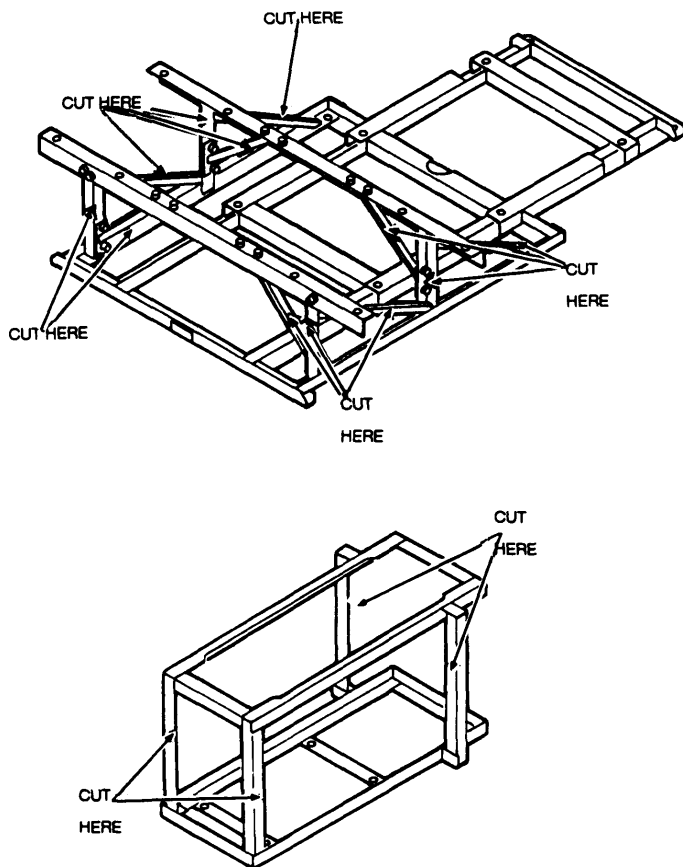

Figure 3-36. Cutting Locations for Frame Assembly - M288 Mounting Kit, Smoke Generator.

**3-30. Filter Units, Gas-Particulate: 12 cfm and 20 cfm.**

**WARNING**

When using demolition or fire as a method of destruction-for chemically contaminated equipment (alarms, filters, etc.) personnel should mask and move upwind of the site. If unable to move upwind of the site, personnel must wear protective clothing and masks.

**a. Filter Units.**

FILTER UNIT, GAS-PARTICULATE: Armored Ambulance, 12 CFM, M14 (not installed)

FILTER UNIT, GAS-PARTICULATE: Hospital, 12 CFM, ABC-M7A1

FILTER UNIT, GAS-PARTICULATE: Tank, 12 CFM, ABC-M8A2 and ABC-M8A3 (not installed)

FILTER UNIT, GAS-PARTICULATE: Tank, EMD, 20 CFM, M13 and M13A1 (not installed)

**b. Priorities for Destruction:**

- (1) Air purifier (12 cfm) or precleaned and particulate filter assembly (20 cfm)
- (2) M13A1 headpieces
- (3) Hose assemblies
- (4) Transformer (M7A1) or circuit breaker and switch
- (5) M3 heater and M18 gas filter (M13 and M13A1).

**c. Preferred Methods of Destruction.** Mechanical means and fire.

**d. Mechanical Means.** See paragraph 2-8.

**e. Fire (para 2-14).** Burn with combustible materials.

### 3-31. Filter Unit, Gas-Particulate: Gas-Engine Driven, 300 cfm, ABC-M6A1

#### WARNING

When using demolition or fire as a method of destruction for chemically contaminated equipment (alarms, filters, etc), personnel should mask and move upwind of the site. If unable to move upwind of the site, personnel must wear protective clothing and masks.

#### a. Priorities for Destruction:

- (1) Engine
- (2) Filters
- (3) Carburetor
- (4) Blower casing
- (5) Hose assemblies

**b. Preferred Methods of Destruction.** Mechanical means, demolition, and fire.

**c. Mechanical Means.** See paragraph 2-8.

**d. Demolition (para 2-11).**

#### NOTE

The ABC-M6A1 gas-particulate filter unit can be installed either outside or inside a shelter. Designation of air inlet or outlet on this equipment depends upon type of installation.

Fasten 1/2-pound explosive charges at as many of the following locations on the filter unit (3-38) as time permits. (Outside installation is shown.) Detonate charges at the same time.

- (1) On (or in) blower
- (2) On (or in) canister air inlet and outlet
- (3) On engine
- (4) Under canister assembly

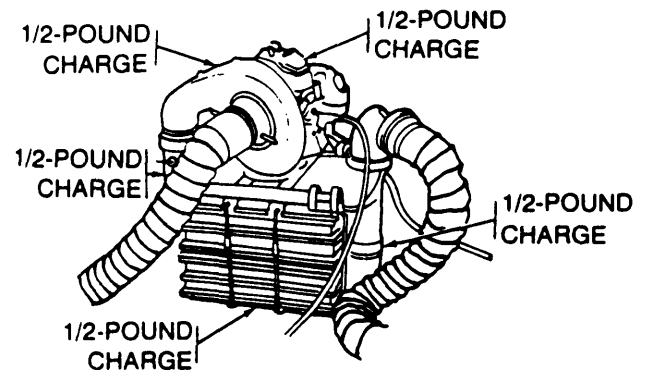

Figure 3-38. Explosive Charge Locations for ABC-M6A1 Gas-Particulate filter Unit.

#### e. Fire (para 2-14).

- (1) Fasten incendiary grenade on top of blower, engine, and canister assembly.
- (2) Ignite grenades with lanyards.

### 3-32. Gas-Particulate Filter Units in Support of Fixed Installations.

#### WARNING

When using demolition or fire as a method of destruction for chemically contaminated equipment (alarms, filters, etc), personnel should mask and move upwind of the site. If unable to move upwind of the site, personnel must wear protective clothing and masks.

#### a. Filter Units.

FILTER UNIT, GAS-PARTICULATE: EMD, 600 CFM, M9A2

FILTER UNIT, GAS-PARTICULATE: EMD, 1200 CFM, M10A2

FILTER UNIT, GAS-PARTICULATE: EMD, 2500 CFM, M11A2

FILTER UNIT, GAS-PARTICULATE: EMD, 5000 CFM, M12A2

**b. Priorities for Destruction:**

- (1) Motor-blower assembly
- (2) Particulate assembly
- (3) Gas filters
- (4) Motor starter
- (5) Flexible tubing transition

**c. Preferred Methods of Destruction.** Mechanical means, demolition, and fire.

**d. Mechanical Means.** See paragraph 2-8.

**e. Demolition (para 2-11).** Fasten 1-pound charges at as many of the following locations on the filter unit(3-39)as time permits. Detonate all charges at the same time.

- (1) Under motor-blower assembly
- (2) In motor-blower inlet
- (3) Under particulate filter
- (4) Under gas filter
- (5) In filter inlet transition. Cut opening in transition fabric for this charge.
- (6) In flexible tubing transition next to gas filter.

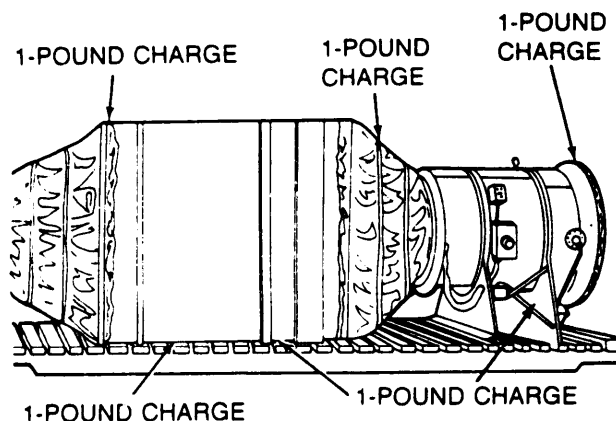

Figure 3-39. Explosive Charge Locations for M9A2/M10A2/M11A2/M12A2 Gas-Particulate Filter Unit - Typical Fixed Installation.

**f. Fire (pars 2-14).**

- (1) Fasten incendiary grenades above key components specified above.
- (2) Ignite grenades with lanyards.

**3-33. Protective Masks, Hoods, and Outfits.**

**WARNING**

When using demolition or fire as a method of destruction for chemically contaminated equipment (alarms, filters, etc), personnel should mask and move upwind of the site. If unable to move upwind of the site, personnel must wear protective clothing and masks.

**a. Priorities for Destruction.**

**(a) Masks.**

- MASK, CHEMICAL-BIOLOGICAL Aircraft, M43
- MASK, CHEMICAL-BIOLOGICAL: Combat Vehicle, M42
- MASK, CHEMICAL-BIOLOGICAL: Field, M40
- (1) Facepiece Assembly and Canisters
- (2) Blower
- MASK, CHEMICAL-BIOLOGICAL: Aircraft, ABC-M24
- MASK, CHEMICAL-BIOLOGICAL: Field, ABC-M17 and M17A1
- MASK, CHEMICAL-BIOLOGICAL: Headwound, ABC-M18
- MASK, CHEMICAL-BIOLOGICAL: Special Purpose, M9 and M9A1
- MASK, CHEMICAL-BIOLOGICAL: Tank, M25 and M25A1
- MASK, GAS: Acid and Organic Vapors, M10
- MASK, GAS: All-Purpose, M11A1
- MASK, GAS: Ammonia, M12

**(b) Hoods.**

- HOOD, CHEMICAL-BIOLOGICAL MASK: Aircraft, ABC-M7
- HOOD, CHEMICAL-BIOLOGICAL MASK: Field, M6 and ABC-M6A2
- HOOD, CHEMICAL-BIOLOGICAL MASK: Tank, ABC-M5

**(c) Outfits.**

- PROTECTIVE OUTFIT, TOXICOLOGICAL, MICROCLIMATIC CONTROLLED
- (3) Chemical-biological masks, canisters, and filters
- (4) Protective outfits, canisters, and filters
- (5) Hoods
- (6) Gas masks and canisters

**b. Preferred Methods of Destruction.** Mechanical means and fire.

**NOTE**

Divisional or higher commanders may authorize personnel to retain their individual protective equipment if the tactical situation or intelligence indicates a need for chemical-biological protection.

**c. Mechanical Means.** See paragraph 2-8.

(1) For the Chemical-Biological Mask: Aircraft M43, Chemical-Biological Mask: Combat Vehicle M42, and Chemical-Biological Mask: Field M40, if time permits, deform the thread area of the canister (3-40) without rupturing the canister cover.

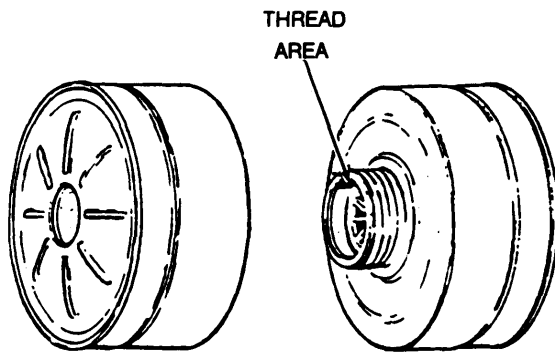

Figure 3-40. Thread area and canister cover for Mask: Chemical-Biological, M40, M42, M43.

**d. Demolition (para 2-11).** For the Chemical-Biological Mask: M43, remove the battery from the blower (3-41) Place 1/4 pound charge in the battery housing.

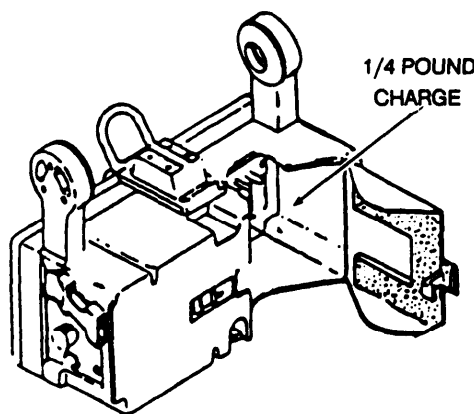

Figure 3-41. Explosive Charge Location for Battery Housing Unit - Mask, Chemical-Biological: Aircraft, M43.

**e. Fire (para 2-14).** Burn with combustible materials. For the Chemical-Biological Mask: M43, remove the battery from the blower and fasten an incendiary grenade to the battery housing. Ignite with lanyards.

**3-34. Radioactive Sources.**



Radiation hazard. Do not use mechanical means, demolition, fire, gunfire, or dumping in water to destroy radioactive sources. Exposure to radiation from the source may cause casualties or deaths.

**a. Radioactive Sources.**

- CALIBRATOR; RADIAC: AN/UDM-6
- CALIBRATOR, RADIAC: AN/UDM-7B
- CALIBRATOR, RADIAC: TS-1230A
- Calibrator SET, RADIAC: AN/UDM-1 and 1A
- RADIOACTIVE SOURCE SET: M3A1

**b. Preferred Method of Destruction.** Use natural surroundings, except dumping in water.

**c. Use of Natural Surroundings.** See paragraph 2-23.

**3-35. Chemical Agent Monitor System (CAM), M1**



Radiation hazard. Do not use mechanical means, demolition, fire, gunfire, or dumping in water to destroy radioactive sources. Exposure to radiation from the source may cause casualties or deaths.

When using demolition or fire as a method of destruction for chemically contaminated equipment (alarms, filters, etc.), personnel should mask and



move upwind of the site. If unable to mow upwind of the site, personnel must wear protective clothing and masks.

**a. Monitor Kit, CAM.**

- Harness Assembly, carry (1B)
- Nozzle, filtered (1C)
- Monitor, Chemical Agent (1A)
- Case Assembly, carry (1D)

**b. Cap Assembly, nozzle (3)**

**c. Confidence sample (2)**

**d. Priorities for Destruction.**

- (1) Monitor, Chemical Agent
- (2) Nozzle, filtered
- (3) case assembly, carry
- (4) Harness assembly
- (5) Cap assembly, nozzle
- (6) Confidence sample

**e. Preferred Methods of Destruction.** Mechanical means, demolition, and fire. Always remove drift tube module and battery from the chemical agent monitor before using these methods. The drift tube module contains radioactive materials. The battery contains lithium sulfur dioxide and electrolytes. Do not crush or burn battery. Discard drift tube module and battery by using natural surroundings for destruction, e.g., burying (para. 2-23).

Carrying case assembly, harness assembly, and nozzle filter can be destroyed by burning. Nozzle cap assembly can be crushed before discarding. Confidence sample can be dumped on ground with no harm. The container for the confidence sample should be crushed to destroy.

**f. Mechanical means.** See paragraph 2-8.

**g. Demolition (para 2-11).** Place 1/4-pound charge between the handle and the base of the CAM as indicated in figure.

**h. Fire (para 2-14).**

(1) If time permits, build fire with combustible materials and ignite using fire starter or incendiary grenade.

(2) For hasty destruction, fasten incendiary grenades at locations specified for charges above. Ignite grenades by using lanyards.

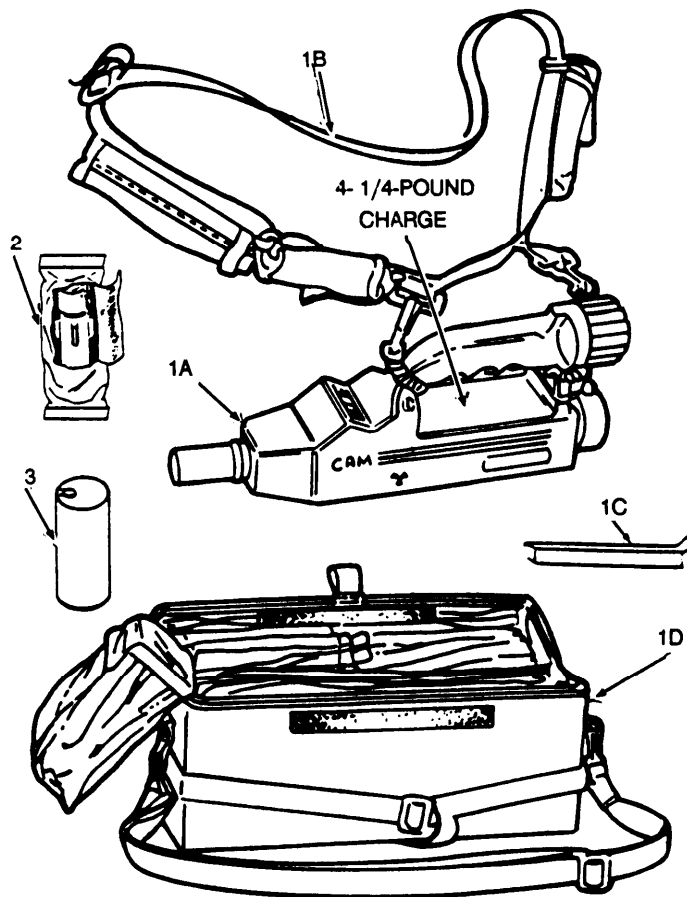

Figure 3-42. Chemical Agent Monitor System. (1A) - Chemical Agent Monitor. (1B) - Carrying Harness Assembly, (1C) - Filtered Nozzle, (1D) - Carrying Case Assembly. (2) - Confidence Sample. (3) - Nozzle Cap Assembly. (4) - Explosive Charge Location for Chemical Agent Monitor System.

**3-36. Modular Collective Protection Equipment.**

**a. Priorities for Destruction.**

PROTECTIVE ENTRANCE CONTROL MODULE (NSN 4240-01-048-2803)

POWER DISTRIBUTION UNIT (NSN 4240-01-068-8615)

CONTROL MODULE (NSN 4240-01-158-5904)

COMPARTMENT CONTROL MODULE (NSN 4240-01-057-3378)

(1) Panel

M5 CONVERTER, FREQUENCY, STATIC (NSN 4240-00-394-9571)

(1) Filters, Radio Frequency (inputs & output plugs)

(2) Electronic components within  
AIRFLOW VALVE (NSN 4240-01-055-1493)

(1) Gear case motor

**b. Preferred Methods of Destruction.** Mechanical means, demolition, and fire.

**c. Mechanical Means.** See paragraph 2-8.

**d. Demolition (para 2-11).** Fasten 1/4 pound explosive charge at the following locations.

(1) Protective Entrance Control Module (NSN 4240-01-048-2803)

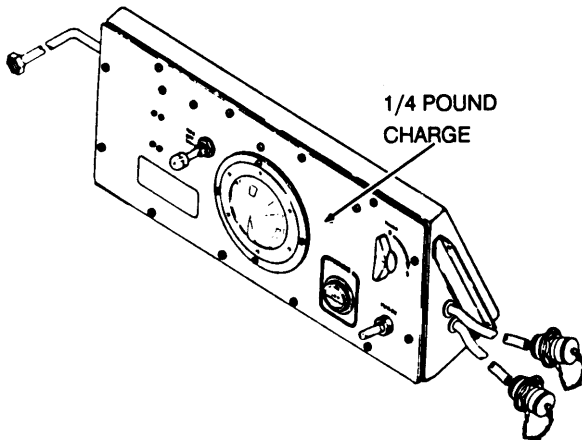

Figure 3-43. Explosive Charge Location for Protective Entrance Control Module - Modular Collective Protection Equipment.

(2) power Distribution Unit (NSN 4240-01-068-8645)

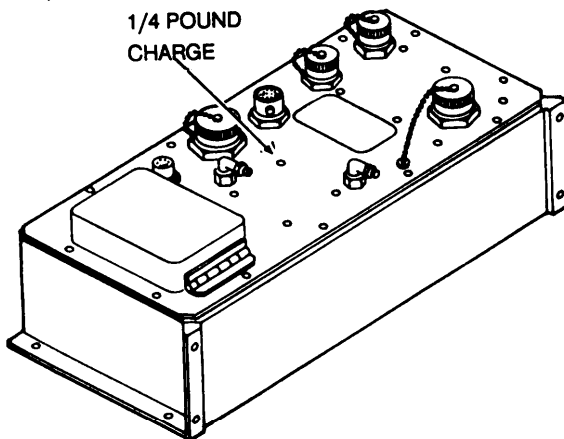

Figure 3-44. Explosive Charge Location for Power Distribution Unit - Modular Collective Protection Equipment.

(3) Control Module (NSN 4240-01-158-5904)

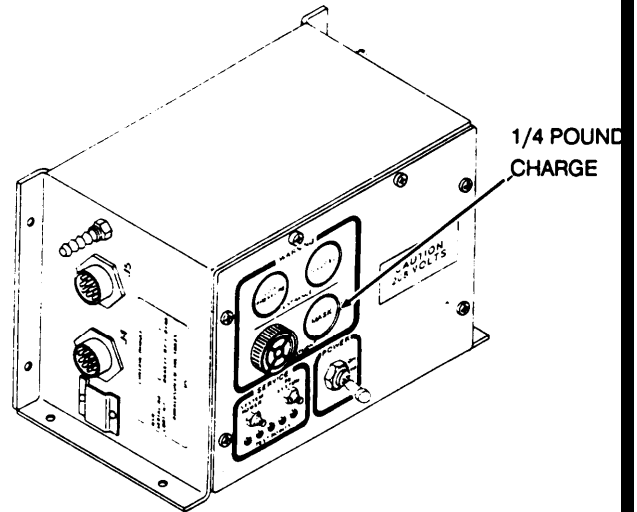

Figure 3-45. Explosive Charge Location for Control Module - Modular Collective Protection Equipment.

(4) Compartment Control Module (NSN 4240-01-057-3378)

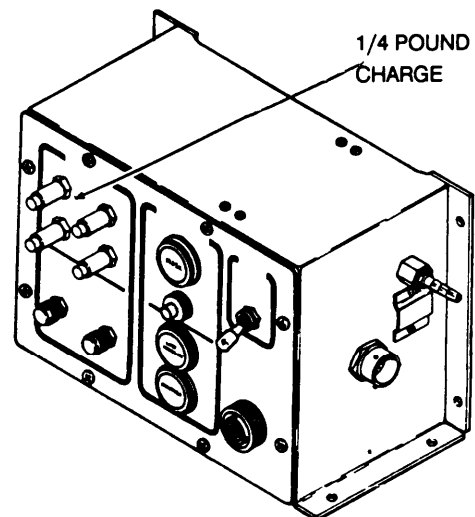

Figure 3-46. Explosive Charge Location for Compartment Control Module - Modular Collective Protection Equipment.

(5) M5 Converter, Frequency, Static (NSN 4240-00-394-9571)

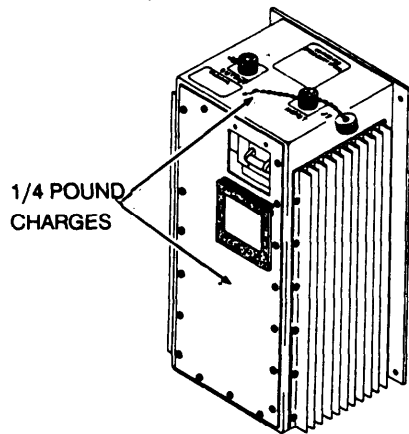

Figure 3-47. Explosive Charge Location for M5 Converter, Frequency, Static - Modular Collective Protection Equipment.

(6) Airflow Valve (NSN 4240-01-055-1493)

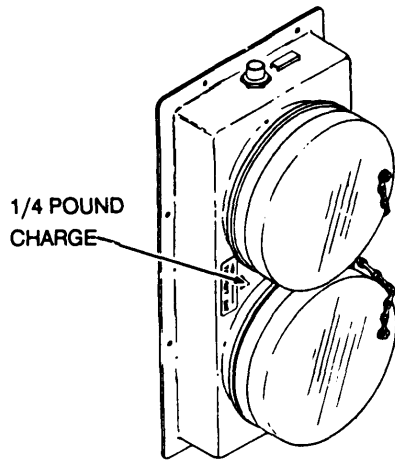

Figure 3-48. Explosive Charge Location for Airflow Valve - Modular Collective Protection Equipment.

**3-37. Shelter System, Collective Protection, Chemical-Biological: inflatable, Trailer Transported, M51**

**WARNING**

When using demolition or fire as a method of

destruction for chemically contaminated equipment (alarms, filters, etc), personnel should mask and move upwind of the site. if unable to move upwind of the site, personnel should wear protective clothing and masks.

**a. Priorities for Destruction.**

- (1) Engine and gas-particulate filter units
- (2) Main control panel
- (3) Entrance
- (4) Shelter
- (5) Air ducts and wiring

**b. Preferred Methods of Destruction.** Mechanical means, demolition, fire, and gunfire.

**c. Mechanical Means.** See paragraph 2-8.

**d. Demolition (para 2-11).** Fasten explosive charges at as many of the following locations on the M51 shelter system (349) as time permits. Detonate all charges at the same time.

- (1) Place 2-pound charge on M68 filter and utilities unit. if rest of system is already loaded on trailer, detonating this size charge will destroy entire M51 shelter system.
- (2) Place 1/2-pound charge on entrance gas-particulate filter unit.
- (3) Place 1/2-pound charge above entrance.
- (4) Place 1/2-pound charge on top of shelter.

**e. Fire (para 2-14).**

- (1) Fasten incendiary grenades at locations specified for charges above. Use two grenades for M68 filter and utilities unit.
- (2) If time permits, build fire with combustible materials.
- (3) Use lanyards to ignite grenades.

**f. Gunfire (para 2-17).**

- (1) Shoot at M68 filter and utilities unit and entrance gas-particulate filter unit until destroyed.
- (2) Fire through shelter and entrance.
- (3) Use flamethrowers or incendiary rockets if available (para 2-13, 2-14, and 2-16).

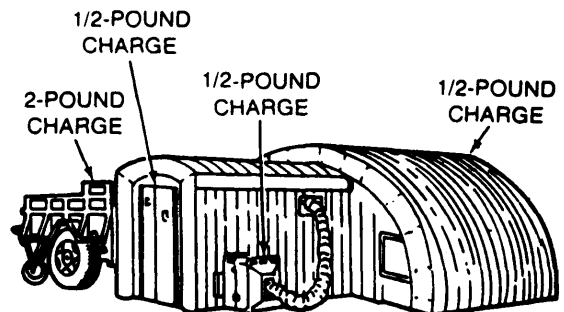

Figure 3-49. Explosive Charge Locations for M51 Shelter System.

## APPENDIX A

### REFERENCES

---

**A-1. Scope.** This appendix lists all forms, field manuals, and technical manuals referenced in this manual.

#### **A-2. Army Regulations.**

Compressed Gases and Gas Cylinders . . . . .	AR 700-68
Ionizing Radiation Protection . . . . .	AR 385-11
Malfunctions involving Ammunition and Explosives . . . . .	AR 75-1
Policies and Procedures for Firing Ammunition for Training, Target Practice, and Combat . . . . .	AR 385-63

#### **A-3. Standardization Agreements.**

Destruction of Military Technical Equipment . . . . .	STANAG 2113
---	-------------

#### **A-4. Technical Manuals.**

Ammunition and Explosives Standards . . . . .	TM9-1300-206
Destruction of Conventional Ammunition and Improved Conventional Munitions to Prevent Enemy Use (Excluding Toxic and Incapacitating Chemical Agents) (For Combat Units) . . . . .	TM 750-244-5-1
Flame Fuels . . . . .	TM 3-366
Operator' sand Organizational Maintenance Manual for Grenades . . . . .	TM 9-1330-200-12
Operator's and Organizational Maintenance Manual (Including Repair Parts and Special Tools List) : Demolition Materials . . . . .	TM 9-1375-213-12
Operator's and Organizational Maintenance Manual (Including Repair Parts and Special Tools List): Launcher, Rocket: 66mm, 4-Tube, M202A1 (NSN 1055-00-021-3909) . . . . .	TM 3-1055-456-12
Storage, Shipment, Handling, and Disposal of Chemical Agents and Hazardous Chemicals . . . . .	TM 3-250

#### **A-5. Field Manuals.**

(C) Boobytraps (U) . . . . .	FM 5-31
Combat Flame Operations . . . . .	FM 20-33
Explosives and Demolitions . . . . .	FM 5-25
First Aid for Soldiers . . . . .	FM 21-11

#### **A-6. Supply Bulletins.**

Requisition and Issue of Cryptographic Equipment Destroyer, Incendiary:TH4, M1A2; Grenade, Hand, incendiary: TH3, AN-M14; Document Destroyer, Emergency, incendiary: M4 and File Destroyer, Incendiary: ABC-M4 . . . . .	SB 725-1300-1
--	---------------

#### **A-7. FORMS.**

Recommended Changes to Publications and Blank Forms . . . . .	DA Form 2028
---	--------------

## ALPHABETICAL INDEX

Subject	Page	Subject	Page
<b>A</b>			
Alarm, Chemical Agent Automatic: Portable Manpack, M8 and M8A1 and Accessories..	3-8	Demolition, Destruction by .....	2-2
Ammunition .....	1-1	Demolition, Required Materials .....	2-3
Area Predictor and Calculators .....	3-11	Detector and Sampling Kits and Supplies.....	3-17
Associated Classified Documents .....	1-2	Disperser, Riot Control Agent, Helicopter or Vehicle Mounted: M5.....	3-2
Authorization .....	1-1	Disperser, Riot Control Agent Portable: M3, M33, M33A1 .....	3-3
<b>B</b>			
Boobytrapping .....	2-1	<b>E</b>	
Breathing Apparatus, Compressed Air: M15 .....	3-11	Entrance, Protective Pressurized, Collapsible: M10 and M12.....	3-13
Breathing Apparatus, Oxygen-Generating: M20 and M20A1 .....	3-11	Equipment Installed in Vehicles .....	1-1
Breathing Apparatus, Self-Contained: M23 M23 and M23A1 .....	3-12	<b>F</b>	
<b>C</b>			
Calculators and Area Predictors .....	3-1	Filter Unit, Gas-Particulate: 12 cfm and 20 cfm .....	3-18
Chemical Agent Monitor (CAM) .....	3-21	Filter Unit, Gas-Particulate: 200 cfm, 208V, 400 Hz, M56 .....	3-14
Chemical Weapons and Support Equipment .....	3-1	Filter Unit, Gas-Particulate: Gas Engine Driven, 300 cfm, ABC-M6A1 .....	3-19
Classified Documents and Equipment .....	1-1	Fire, Destruction by.....	2-5
Classified Equipment .....	1-2	Fire, Procedures for Using.....	2-6
Collective Protection Equipment, CBR: Battery Control Central; Hawk, M10...3-12	3-12	Fire, Required Materials.....	2-5
Combining Methods, Destruction by .....	2-10	Flame Thrower, Portable: M2A1, M9-7, and M9A1 -7 .....	3-3
Combining Methods, Procedures .....	2-10	<b>G</b>	
Compressor Unit, Reciprocating .....	3-1	Gas-Particulate Filter Units in Support of Fixed Installations .....	3-19
Cryptographic Equipment and Material .....	1-2	Generator, Smoke, Mechanical: Pulse Jet, M3A3 (Deleted) .....	3-4
<b>D</b>			
Decontaminating Apparatus, Portable: ABC-M11 .....	3-15	Generator, Smoke, M3A4 .....	3-4
Decontaminating Apparatus, Power-Driven, Skid-Mounted: M12A1 .....	3-15	Gunfire, Destruction by.....	2-8
Decontaminating Apparatus, Portable: Type A/E32U-8 .....	3-16	Gunfire, Procedures.....	2-9
Decontaminating Kit, Equipment, M280 .....	3-17	Gunfire, Required Materials .....	2-8
Decontaminating Kit, Skin, M291 .....	3-17	<b>H</b>	
Decontaminating Kit, Skin, M258A1 .....	3-17	Hoods, Outfits and Protective Masks.....	3-20

Subject	Page
I	
Improper Operation, Destruction by . . . . .	2-9
Improper operation, Procedures . . . . .	2-9
Improper Operation, Required Materials . . .	2-9
L	
Launcher, Grenade Smoke: Screening, RP, M239 and M250 . . . . .	3-5
Launcher, Grenade Smoke: Screening, RP, M243, M257, M259 . . . . .	3-6
M	
Mechanical Means, Destruction by . . . . .	2-1
Mechanical Means, Procedures . . . . .	2-2
Mechanical Means, Required Materials . . . .	2-2
Methods of Destruction . . . . .	1-2, 2-1
Modular Collective Protection Equipment . . . . .	3-22
Mounting Kit, M288 Smoke Generator . . . . .	3-18
N	
Natural Surroundings, Procedures . . . . .	2-10
Natural Surroundings, Required Materials . . . . .	2-9
Natural Surroundings, Use of . . . . .	2-9
NBC Marking Set . . . . .	3-7
O	
Outfits, Protective Masks, and Hoods . . . . .	3-20
P	
Priorities for Destruction of Parts of Military Technical Equipment . . . . .	1-2
Procedures, Combining Methods . . . . .	2-10
Procedures, Demolition . . . . .	2-3
Procedures, Fire . . . . .	2-6
Procedures, Gunfire . . . . .	2-9
Procedures, Improper Operation . . . . .	2-9
Procedures, Mechanical Means . . . . .	2-9
Procedures, Natural Surroundings . . . . .	2-10
Protective Masks, Hoods, and Outfits . . . . .	3-20

Subject	Page
R	
Radioactive Sources . . . . .	3-21
References . . . . .	A-1
Repair Parts . . . . .	1-2
Reporting Destruction . . . . .	1-1
Reporting of Errors . . . . .	1-1
Required Materials, Demolition . . . . .	2-3
Required Materials, Fire . . . . .	2-5
Required Materials, Gunfire . . . . .	2-8
Required Materials, improper Operation . . .	2-9
Required Materials, Mechanical Means . . . .	2-2
Required Materials, Natural Surroundings . . . . .	2-9
S	
Safety Precautions . . . . .	2-1
Scope . . . . .	1-1
Service Kit, Portable, Flame Thrower - Riot Control Agent Dispenser: M27 . . . . .	3-6
Service Kit, Portable Riot Control Agent Dispenser: M254 . . . . .	3-6
Shelter System, Collective Protection, Chemical-Biological: Inflatable, Trailer- Transported, M51 . . . . .	3-24
Smoke Generating Subsystem, Helicopter: M52 . . . . .	3-6
Special Problems . . . . .	1-1
T	
Technical Manuals and Logbooks . . . . .	1-1
Training . . . . .	2-1
Training Equipment and Supplies . . . . .	1-2

**By Order of the Secretary of the Army:**

**Official:**

**E. C. MEYER**  
*General, United States Army*  
*Chief of Staff*

**ROBERT M. JOYCE**  
*Major General, United States Army*  
*The Adjutant General*

**Distribution:**

To be distributed in accordance with DA Form 12-28 requirements for General Information Applicable to all Organizations Which Have a Chemical Mission.

RECOMMENDED CHANGES TO EQUIPMENT TECHNICAL PUBLICATIONS



THEN...JOT DOWN THE DOPE ABOUT IT ON THIS FORM. CAREFULLY TEAR IT OUT, FOLD IT AND DROP IT IN THE MAIL.

SOMETHING WRONG WITH PUBLICATION

FROM: (PRINT YOUR UNIT'S COMPLETE ADDRESS)

DATE SENT

PUBLICATION NUMBER

PUBLICATION DATE

PUBLICATION TITLE

BE EXACT PIN-POINT WHERE IT IS

PAGE NO.

PARA-GRAPH

FIGURE NO.

TABLE NO.

IN THIS SPACE, TELL WHAT IS WRONG AND WHAT SHOULD BE DONE ABOUT IT.

TEAR ALONG PERFORATED LINE

PRINTED NAME, GRADE OR TITLE AND TELEPHONE NUMBER

SIGN HERE



# THE METRIC SYSTEM AND EQUIVALENTS

## WEIGHT MEASURE

1 Centimeter = 10 Millimeters = 0.01 Meters = 0.3937 Inches  
 1 Meter = 100 Centimeters = 1000 Millimeters = 39.37 Inches  
 1 Kilometer = 1000 Meters = 0.621 Miles

## WEIGHTS

1 Gram = 0.001 Kilograms = 1000 Milligrams = 0.035 Ounces  
 1 Kilogram = 1000 Grams = 2.2 lb.  
 1 Metric Ton = 1000 Kilograms = 1 Megagram = 1.1 Short Tons

## LIQUID MEASURE

1 Milliliter = 0.001 Liters = 0.0338 Fluid Ounces  
 1 Liter = 1000 Milliliters = 33.82 Fluid Ounces

## SQUARE MEASURE

1 Sq. Centimeter = 100 Sq. Millimeters = 0.155 Sq. Inches  
 1 Sq. Meter = 10,000 Sq. Centimeters = 10.76 Sq. Feet  
 1 Sq. Kilometer = 1,000,000 Sq. Meters = 0.386 Sq. Miles

## CUBIC MEASURE

1 Cu. Centimeter = 1000 Cu. Millimeters = 0.06 Cu. Inches  
 1 Cu. Meter = 1,000,000 Cu. Centimeters = 35.31 Cu. Feet

## TEMPERATURE

$5/9(^{\circ}\text{F} - 32) = ^{\circ}\text{C}$   
 212° Fahrenheit is equivalent to 100° Celsius  
 90° Fahrenheit is equivalent to 32.2° Celsius  
 32° Fahrenheit is equivalent to 0° Celsius  
 $9/5^{\circ}\text{C} + 32 = ^{\circ}\text{F}$

## APPROXIMATE CONVERSION FACTORS

TO CHANGE	TO	MULTIPLY BY
Inches	Centimeters	2.540
Feet	Meters	0.305
Yards	Meters	0.914
Miles	Kilometers	1.609
Square Inches	Square Centimeters	6.451
Square Feet	Square Meters	0.093
Square Yards	Square Meters	0.836
Square Miles	Square Kilometers	2.590
Acres	Square Hectometers	0.405
Cubic Feet	Cubic Meters	0.028
Cubic Yards	Cubic Meters	0.765
Fluid Ounces	Milliliters	29.573
its	Liters	0.473
arts	Liters	0.946
allons	Liters	3.785
Ounces	Grams	28.349
Pounds	Kilograms	0.454
Short Tons	Metric Tons	0.907
Pound-Feet	Newton-Meters	1.356
Pounds per Square Inch	Kilopascals	6.895
Miles per Gallon	Kilometers per Liter	0.425
Miles per Hour	Kilometers per Hour	1.609

TO CHANGE	TO	MULTIPLY BY
Centimeters	Inches	0.394
Meters	Feet	3.280
Meters	Yards	1.094
Kilometers	Miles	0.621
Square Centimeters	Square Inches	0.155
Square Meters	Square Feet	10.764
Square Meters	Square Yards	1.196
Square Kilometers	Square Miles	0.386
Square Hectometers	Acres	2.471
Cubic Meters	Cubic Feet	35.315
Cubic Meters	Cubic Yards	1.308
Milliliters	Fluid Ounces	0.034
Liters	Pints	2.113
Liters	Quarts	1.057
ers	Gallons	0.264
ms	Ounces	0.035
ograms	Pounds	2.205
Metric Tons	Short Tons	1.102
Newton-Meters	Pounds-Feet	0.738
Kilopascals	Pounds per Square Inch	0.145
ometers per Liter	Miles per Gallon	2.354
ometers per Hour	Miles per Hour	0.621

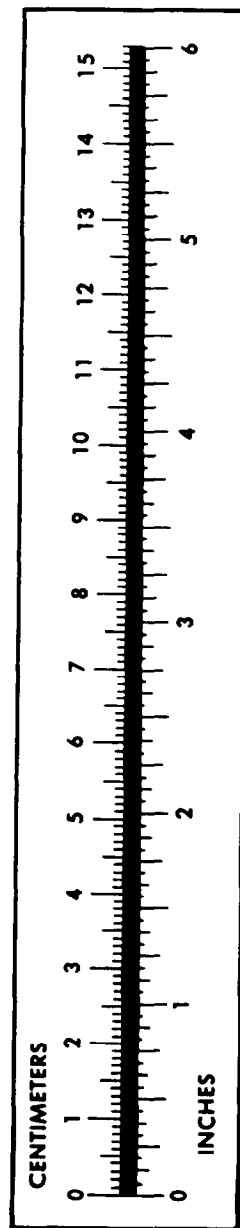

**PIN: 019735-001**